



## TPE Series Electric and TPA Series Air Torque Wrench Pumps

### Usage:

The Zinko TPE series Electric Pumps are a perfect match to the Zinko TRS and TRH series Torque Wrenches. Available in many configurations the TPE series can operate using 115V or 230V, come in 2.1 gallon or 5.2 gallon reservoirs and there are many options to allow the use of more than one Torque wrench at a time.

### Features:

- External adjustable pressure regulator and gauge allow user to easily change torque settings.
- Low pressure setting on retract function protects torque wrenches.
- Can be ordered with various manifolds to handle 1, 2, 3, or 4 torque wrenches to operate simultaneously.
- Timer function allows pump to be set to automatically stop after 20, 40, or 60 seconds.
- Equipped with safety start switch to help eliminate accidental pump operation.
- Optional pump cooling kit available to keep pump within safe operating temperatures during extended operation.

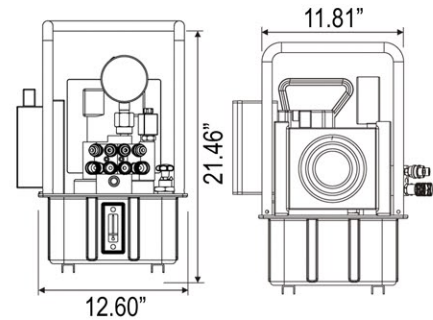

Model Number	Rpm	DBa at Idle and 10,000 PSI	Motor (HP)	Amps @ 10,000 PSI	Flow rate (in <sup>3</sup> /min.)				Capacity Gallons	Usable Gallons	Weight (with oil) (lbs.)
					PSI						
					0	700	5,000	10,000			
TPE-84	12000	80	1 1/8	25 /110V	690	433	73	55	2.1	1.85	70.4
				13 /230V							

Options: Voltage: 115V or 230V. Reservoir size; 2.1 Gallon or 5.2 Gallon. Manifold: 1,2,3 or 4 sets of couplers. Speak with a sales representative to customize power unit.

### Usage:

The Zinko TPA series Air Pumps are a perfect match to the Zinko TRS and TRH series Torque Wrenches when air is the preferred power source.

### Features:

- External adjustable pressure regulator and gauge to easily change torque settings.
- Low pressure setting on retract function protects torque wrenches.
- Can be ordered with various manifolds to handle 1, 2, 3, or 4 torque wrenches to operate simultaneously.
- Powerful 4 Hp air motor can start even under a full load
- 15 ft long pneumatic remote control allows for easy activation of pump.

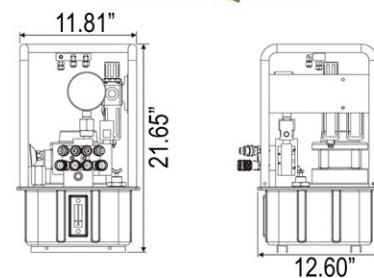

Model Number	Air Supply Req'd (ft <sup>3</sup> / min.)	Rpm	DBa at Idle and @ 10,000 PSI	Motor (Hp)	Flow rate (in <sup>3</sup> / min.)				Capacity Gallons (usable)	Weight (with oil) (lbs.)
					PSI					
					0	700	5,000	10,000		
TPA-300	49.44	3,000	75	4	452	79	67	55	2.1 (1.85)	80