

TITAN E+ ELECTRIC HYDRAULIC PUMP 10,000 PSI



NOTE:

- Carefully inspect the pump upon arrival. The carrier, not the manufacturer, is responsible for any damage resulting from shipment.
- Read and carefully follow these instructions. Most problems with new equipment are caused by improper operation or installation.
- The hydraulic power unit can be ordered with "building block" flexibility. The customer can choose from a variety of motors, controls, reservoirs, and other options. Because of the many options available, these instructions will include directions for options that your particular pump may not have.
- Do not change motors without consulting the pump manufacturer's Technical Services Department.

SAFETY PRECAUTIONS

 **WARNING:** To help prevent personal injury,

HYDRAULIC HOSE

- Before operating the pump, all hose connections must be tightened with the proper tools. Do not overtighten. Connections should only be tightened securely and leak-free. Overtightening can cause premature thread failure or high pressure fittings to split at pressures lower than their rated capacities.
- Always shut off the electric motor before breaking any connections in the system.
- Should a hydraulic hose ever rupture, burst, or need to be disconnected, immediately shut off the pump. Never attempt to grasp a leaking pressurized hose with your hands. The force of escaping hydraulic fluid could cause serious injury.
- Do not subject the hose to potential hazard such as fire, sharp surfaces, extreme heat or cold, or heavy impact. Do not let the hose kink, twist, curl or bend so tightly that oil flow within the hose is blocked or reduced. Periodically inspect the hose for wear, because any of these conditions can damage the hose.
- Do not use the hose to move attached equipment. Stress can damage the hose, causing personal injury.
- Hose material and coupler seals must be compatible with the hydraulic fluid used. Hoses also must not come in contact with corrosive materials such as creosote-impregnated objects and some paints. Consult the manufacturer before painting a hose. Never paint the couplers. Hose deterioration due to corrosive materials can result in personal injury.

PUMP

- Do not exceed the PSI hydraulic pressure rating noted on the pump nameplate or tamper with the internal high pressure relief valve. Creating pressure beyond rated capacities can result in personal injury.
- Before replenishing the oil level, retract the system to prevent overfilling the pump reservoir. An overfill can cause personal injury due to excess reservoir pressure created when the wrenches are retracted.

POWER SUPPLY

- Never use an ungrounded power supply with this unit.
- The pump must be compatible with existing line voltage.
- Disconnect the pump from the power supply when performing maintenance or repair on the unit.
- If the unit's power supply is damaged or the inner wiring is exposed in any way, replace immediately.
- Any electrical work must be done by a qualified electrician.
- If the power cord is damaged or wiring is exposed, replace or repair immediately.
- Changing the voltage on the jet motor (single, or three phase) is a complicated and, if not done correctly, dangerous procedure. Consult the pump manufacturer's Technical Services Department for specific information before attempting any rewiring. Rewiring voids CSA approval.
- All voltages must be wired for CW rotation when viewed from the lead end (top) of the motor.
- Check the *total* amperage draw for the electrical circuit you will be using. (For example: Do not plug a motor or motors that may draw 25 amps into a 20 amp fused electrical circuit.)
- Do not attempt to increase the powerline capacity by replacing a fuse with another fuse of higher value. Overheating of the powerline and the possibility of a fire will result.
- To rewire a motor from one voltage to another or when a flow control valve is changed between manual and solenoid, consult the electrical schematic in the pump's parts list.

Circuit Breakers: If motor stops due to an overload or power outage,

Universal Motor: Move motor switch to OFF and control valve to neutral. Let motor cool or wait until power is restored. Reset circuit breaker switch in power panel. (The pump motor doesn't have a circuit breaker.)

Single-phase Motor: Thermal overload switch will break circuit to the motor. Move motor switch to OFF and control valve to neutral. Allow motor to cool before switching on again, or wait until power is restored.

Three-phase Motor: A magnetic starter switch breaks circuit to the motor. Move the motor switch to OFF and control valve to neutral. Remove the cover on motor control box. Let the motor cool or wait until power is restored. One of three reset buttons must be pushed in to reset motor. Replace cover.

HYDRAULIC PUMP SET-UP PROCEDURE

Motor Hook-up and Operation

Universal Motor: The universal motor is wired for 115 or 230 volts, 50/60 cycles according to the customer's request. **This motor cannot be rewired.**

SET-UP AND OPERATION

Filling The Reservoir

NOTE: The pump has been shipped without oil in the reservoir. High-grade hydraulic oil has been shipped with the pump in a separate container. If additional oil is required, use a high-grade, approved hydraulic oil.

1. Clean the area around the filler cap to remove all dust and grit. Any dirt or dust in the oil can damage the polished surfaces and precision-fit components of the pump.
2. Retract all cylinders to the return position.
3. Remove the filler cap, and insert a clean funnel and filter. Fill with hydraulic oil to 1/2" from the top of the filler hole. Replace filler cap with the breather-hole in the filler cap open.
4. Cycle the pump (with wrench attached) several times. Retract the wrench, and check the oil level in the pump reservoir again.

Hydraulic Connections

1. Clean all the areas around the oil ports of the pump and wrench.
2. Inspect all threads and fittings for signs of wear or damage, and replace as needed.
3. Clean all hose ends, couplers or union ends.
4. Remove the thread protectors from the hydraulic oil outlets. Connect the hose assembly to the hydraulic oil outlet, and couple the hose to the wrench. Although a high-grade, non-hardening thread sealant is preferred, teflon tape may be used to seal hydraulic connections if only one layer of tape is used. Apply carefully to prevent the tape from being pinched by the coupler and broken off inside the pipe end. Any loose pieces of tape could travel through the system and obstruct the flow of oil.

Priming The Pump

When operating the pump for the first time:

1. Valve and hose connections must be tight, and the reservoir must be filled to the proper oil level. Start the motor.
2. Jog the pump several times to build pressure. If the pump doesn't build pressure, it may not be primed. Disconnect a hose from the system and route it back to the pump reservoir. Run the pump until a steady flow of oil is observed free of suspended air bubbles. Reconnect the hose to the system.
3. Run wrench several times to eliminate air from the system. For more complete instructions, refer to the section titled "Bleeding Air From The System."
4. The pump is ready to be put into regular operation.

IMPORTANT: After eliminating trapped air from a large work-holding system, retract the wrenches and refill the pump reservoir to 1/2" from the top of the filler hole.

Adjusting The Pressure Regulating Valve

NOTE: For easy adjustment of the pressure regulating valve, always adjust the pressure by *increasing* to the desired pressure setting.

1. Loosen the locknut on the pressure regulating valve (C), and back the adjusting screw (B) out a few turns with a screwdriver by turning in a counterclockwise direction. This will *decrease* the setting to a lower than desired pressure.
2. The pump must be completely connected. Set the motor control toggle switch on "Run" and push the "Start" button.
3. With the screwdriver, slowly turn the adjusting screw (B) in a clockwise direction. This gradually *increases* the pressure setting. When the desired pressure is reached, lock the adjusting screw in position by tightening the locknut.

IMPORTANT:

- The pressure range is from 1,000 to 10,000 PSI depending on the pump model.

PREVENTIVE MAINTENANCE



WARNING: To help prevent personal injury,

- Disconnect the pump from the power supply before performing maintenance or repair procedures.
- Repairs and maintenance are to be performed in a dust-free area by a qualified technician.

Bleeding Air From The System

Air can accumulate in the hydraulic system if the reservoir oil level is too low. This air causes the wrench to respond in an unstable or slow manner. To remove the air:

1. The hydraulic wrench(s) must be positioned on their side(s) with the couplers located upward.
2. Remove any load from the wrench(s), and cycle the hydraulic system through several cycles (fully extend and retract the wrenches).

Note: The wrench must be at a lower level than the pump to allow air to be released through the pump reservoir

Hydraulic Fluid Level

1. Check the oil level in the reservoir after each 10 hours of use. Proper oil level is 1/2" from the top of the fill hole when all wrenches are retracted.
2. Drain, flush, and refill the reservoir with an approved, high-grade hydraulic oil after approximately every 300 hours of use. The frequency of oil changes will depend upon the general working conditions, severity of use, and overall cleanliness and care given the pump.

Maintenance Cleaning

1. Keep the pump's outer surface as free from dirt as possible.
2. Seal all unused couplers with thread protectors.
3. Keep all hose connections free of dirt and grime.
4. The breather-hole in the filler cap must be clean and unobstructed at all times.
5. Equipment connected to the pump must be kept clean.
6. Use only an approved, high-grade hydraulic oil in this pump. Change as recommended (every 300 hours).

TITAN E+ Operating Instructions

Draining And Flushing The Reservoir

IMPORTANT: Clean the pump exterior before the pump interior is removed from the reservoir.

1. Remove the ten screws fastening the motor and pump assembly to the reservoir. **IMPORTANT: Do not damage the gasket or bump the filter or pressure regulating valves when lifting the pump and motor off the reservoir. See Figure 2.**
2. Clean the inside of the reservoir and fill with a suitable flushing oil. Rinse the filter clean.
3. Place the pump and motor assembly back onto the reservoir, and secure with two machine screws assembled on opposite corners of the housing.

IMPORTANT: The hydraulic flow control valve must be in the neutral position for the following step. If the pump is equipped with a valve that has only an advance or retract position, place the valve in the advance position, and connect a hose to the advance port on the valve. Place the other end of the hose into the oil filler plug hole.

4. Run the pump for several minutes. Then disconnect the motor and pump assembly, and drain and clean the inside of the reservoir.
5. Fill the reservoir with an approved, high-grade hydraulic oil. Place the pump and motor assembly (with gasket) on the reservoir, and thread the ten screws. Tighten securely and evenly.

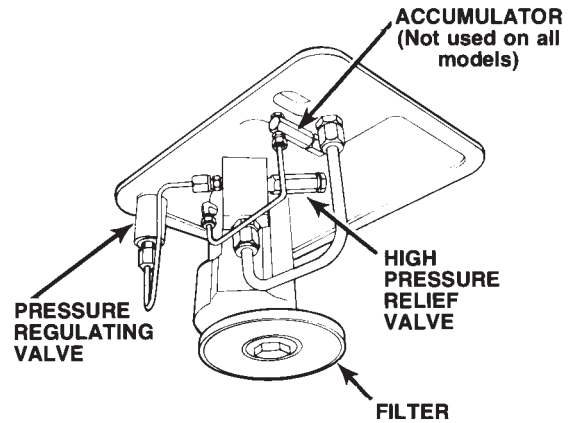

FIGURE 2

Adding Oil To The Reservoir

1. Wrench must be fully retracted and the power supply disconnected when adding oil to the reservoir.
2. Clean the entire area around the filler plug before removing the filler plug.
3. Use a clean funnel with filter when adding oil.
4. Use an approved, high-grade hydraulic oil (215 SSU @ 100° F) only.

Sound Reduction

The electrically-powered hydraulic pump operates in the 90-95 dBA range. If further sound reduction is desirable, any of the following options will help reduce the sound level.

1. Install a pressure switch. It shuts the motor off automatically when maximum pressure is reached (holding cycle).
2. Use a 3450 RPM, 1-1/2 horsepower, 115 VAC, 60 Hz, 1-phase pumping unit.
3. Use a 3450 RPM, 1-1/2 horsepower, 230 VAC, 60 Hz, 3-phase pumping unit.
4. Install casters (two gallon reservoir only) to reduce the noise level.

Checking Brushes On Universal Motors

To help prevent premature failure of the armature, check the brushes periodically:

1. Remove the metal brush cover plates.
2. Remove the brush holder caps and brush assemblies
3. The brush assemblies must be replaced if they are 1/8" long or less. See Figure 3.
4. Install brush assemblies, brush holder caps, and metal brush cover plates.

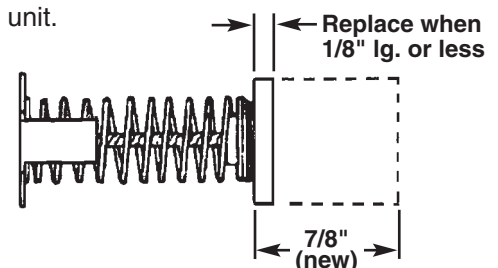
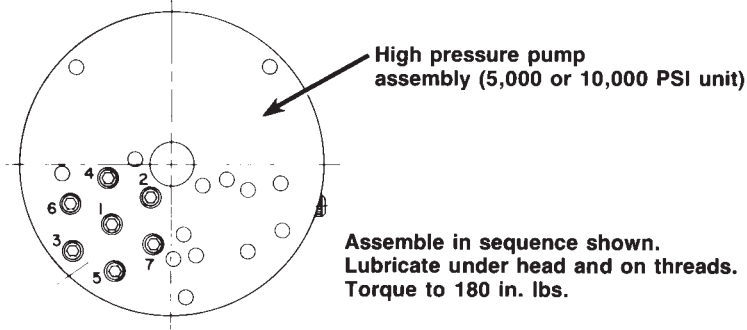

FIGURE 3

REASSEMBLY SPECIFICATIONS

HIGH PRESSURE PUMP ASSEMBLY BOLT TIGHTENING SEQUENCE



BRUSH HOLDER & ARMATURE INSTALLATION SPECIFICATIONS

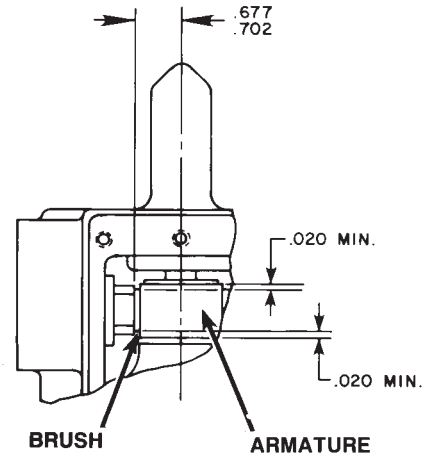

NEEDLE BEARING INSTALLATION SPECIFICATIONS

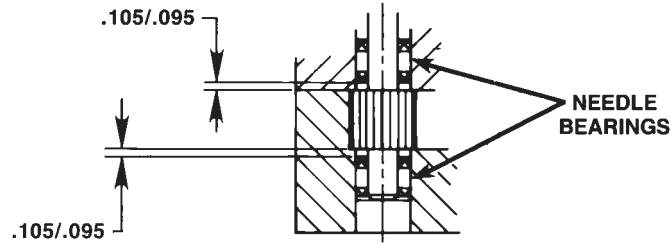

TROUBLESHOOTING GUIDE

 **WARNING**

- To help prevent personal injury, any repair work or troubleshooting must be done by qualified personnel familiar with this equipment.
- Use the proper gauges and equipment when troubleshooting.

NOTE:

- Depending on the type of pump, it is often best to check for leaks by using a hand pump and applying pressure to the suspect area without the motor running. Watch for leaking oil and follow it back to its source.
- Plug the outlet ports of the pump when checking for leakage to determine if the leakage is in the pump or in the wrench or tool.
- Refer to the Parts List included with your particular pump when using this troubleshooting guide.

PROBLEM	CAUSE	SOLUTION
<p>Electric motor does not run</p>	<ol style="list-style-type: none"> 1. Pump not turned ON. 2. Unit is not plugged in. 3. No voltage supply. 4. Broken lead wire or defective power cord plug. 5. Defective switches. 6. Defective motor. 7. Defective starter relay. 8. Defective remote switch. 9. Worn brushes. 10. Circuit breaker tripped because total amperage draw too high for existing circuit. 11. Overheated motor (single-phase motor only). Magnetic starter disengaged (three-phase motor only). Thermal protector open. 12. Faulty thermal protector (single-phase motor). Faulty magnetic starter (three-phase motor). 	<ol style="list-style-type: none"> 1. Flip toggle switch to "Run" position. 2. Plug in unit. 3. Check line voltage. Check reset button on power panel. 4. Replace defective parts. 5. Check switches. 6. Repair or replace motor. 7. Replace defective parts. 8. Repair or replace remote switch. 9. Replace brushes. 10. Add an additional circuit or use alternate circuit. 11. Wait for motor to cool before restarting. Reset thermal protector (Single-phase motor will reset automatically.) 12. Replace.

 **WARNING: To help prevent personal injury, disconnect power supply before removing cover. Any electrical work should be performed by a qualified electrician.**

TITAN E+ Operating Instructions

PROBLEM	CAUSE	SOLUTION
Pump is not delivering oil or delivers only enough oil to advance wrench(s) partially or erratically (continued).	<ol style="list-style-type: none"> 1. Oil level too low. 2. Loose-fitting coupler to wrench. 3. Air in system. 4. Air leak in suction line. 5. Dirt in pump or filter plugged. 6. Oil is bypassing through the double-acting wrench. 7. Cold oil or oil too heavy (Hydraulic oil is of a higher viscosity than necessary). 8. Relief valve or low pressure unloading valve out of adjustment. 9. Reservoir capacity is too small for the size of the wrench(s) used. 10. Defective directional valve. 11. Sheared drive shaft key(s) 12. Motor rotating in wrong direction. 13. Vacuum in reservoir. 14. Low pressure pump worn. 	<ol style="list-style-type: none"> 1. Fill reservoir to 1/2" from top of filler hole with wrench retracted. 2. Check quick-disconnect couplings to wrench. Inspect couplers to ensure that they are completely coupled. Occasionally couplers have to be replaced because the ball check does not stay open due to wear. 3. Bleed the system. 4. Check and tighten suction line. 5. Pump filter should be cleaned and, if necessary, pump should be dismantled and all parts inspected and cleaned. 6. By removing the wrench and capping the hoses, the pump and valve can be checked. Observe if pump holds pressure. 7. Change to a lighter oil. 8. Adjust as needed. 9. Use smaller wrench(s) or larger reservoir. 10. Inspect all parts carefully and replace if necessary. 11. Replace. 12. 3450 RPM motor: Refer to electrical schematic on motor. 12,000 RPM motor: Reverse lead wires to brush holders. Air motor: Air line connected into wrong port. 13. Check for plugged vent in filler plug. 14. Remove end cap from low pressure gear pump. Clean pump, and replace worn gears, shifting spool, body or end cap.

TITAN E+ Operating Instructions

PROBLEM	CAUSE	SOLUTION
Pump builds pressure but cannot maintain pressure.	<ol style="list-style-type: none"> 1. Check to see if there are any external leaks. If no oil leakage is visible, the problem is internal. If using a double-acting wrench, remove it from the system to ensure that the leak is not in the wrench. 2. To test for a leaking control valve, lift the pump from the reservoir but keep the filter in the oil. Remove the drain line to see if the oil is leaking from the valve. If the valve is not leaking, the internal check valve could be leaking. Refer to the note concerning checking for oil leaks at the beginning of this troubleshooting Guide. 3. Leaking pressure switch seal. 	<ol style="list-style-type: none"> 1. Seal leaking pipe fittings with pipe sealant. 2. Clean, reseal or replace flow control valve parts. If the internal check valve(s) are leaking, the pump must be dismantled and the seat areas repaired, poppets replaced, etc. 3. Repair or replace seal.
Pump will not build full pressure.	<ol style="list-style-type: none"> 1. Faulty pressure gauge. 2. Check for external leakage. 3. Check the external pressure regulator. Check the relief valve setting. 4. Look for internal leakage in double-acting wrench. 5. Check for leaks in the flow control valve. 6. Inspect the pump for internal leakage. Check high pressure pump inlet or outlet ball checks. 	<ol style="list-style-type: none"> 1. Calibrate gauge. 2. Seal faulty pipe fitting with pipe sealant. 3. Lift the pump from the reservoir, but keep the filter immersed in oil. Note the pressure reading when the relief valve begins to open. If functioning normally, it should start to leak off at relief valve pressure. 4. Remove the wrench from the pump. If the pump builds full pressure, the wrench is defective. 5. Clean and reseal or replace parts. 6. Same procedure as above, but look for leaks around the entire inner mechanism. If there are no visible leaks, the high pressure pump subassembly may be leaking. Remove all parts. Check the valve head assembly body for any damage to the seat area. Clean and reseal if necessary. Inspect for damage and replace if necessary, then reassemble.

TITAN E+ Operating Instructions

PROBLEM	CAUSE	SOLUTION
Pump will not build full pressure. (Continued)	<ol style="list-style-type: none">7. Sheared key(s).8. Inadequate air pressure (air motor only).9. Shifting spool seat and/or shifting spool poppet (located under high pressure pump assembly) worn.10. Shifting spool o-ring (located within shifting spool bore) worn or broken.	<ol style="list-style-type: none">7. Replace.8. Increase air pressure.9. Clean and reseal or replace.10. With an o-ring pick, remove o-ring and backup washer through low pressure pump assembly end. Replace.
Wrench will not retract.	<ol style="list-style-type: none">1. Check the system pressure; if the pressure is zero, the control valve is releasing pressure and the problem may be in the wrench, mechanical linkage connected to wrench(s), or quick-disconnect couplings.2. Defective valve.3. Inadequate air pressure (air motor model only).	<ol style="list-style-type: none">1. Check the wrench for broken return springs, and check couplers to ensure that they are completely coupled. Occasionally couplers have to be replaced because one check does not stay open in the coupled position.2. Check valve operation and inspect parts. Replace if necessary.3. Increase air pressure.
Pump delivers excess oil pressure.	<ol style="list-style-type: none">1. Faulty pressure gauge.2. Relief valve not properly set.	<ol style="list-style-type: none">1. Calibrate gauge.2. Adjust the relief valve.

RECOMMENDED MINIMUM WIRE SIZE – AWG (mm²)
OF EXTENSION CORDS FOR
TITAN ELECTRIC PUMPS

Current At Full Load (Amps)	Cord Size AWG (mm ²) 3.2 Volt Drop			
	Length of Cord			
	0 - 25 feet (0 - 8 m)	25 - 50 feet (8 - 15 m)	50 - 100 feet (15 - 30 m)	100-150 feet (30 - 45 m)
6	18 (.82)	16 (1.33)	14 (2.09)	12 (3.32)
8	18 (.82)	16 (1.33)	12 (3.32)	10 (5.37)
10	18 (.82)	14 (2.09)	12 (3.32)	10 (5.37)
12	16 (1.33)	14 (2.09)	10 (5.37)	8 (8.37)
14	16 (1.33)	12 (3.32)	10 (5.37)	8 (8.37)
16	16 (1.33)	12 (3.32)	10 (5.37)	8 (8.37)
18	14 (2.09)	12 (3.32)	8 (8.37)	8 (8.37)
20	14 (2.09)	12 (3.32)	8 (8.37)	6 (13.30)
22	14 (2.09)	10 (5.37)	8 (8.37)	6 (13.30)
24	14 (2.09)	10 (5.37)	8 (8.37)	6 (13.30)
26	12 (3.32)	10 (5.37)	8 (8.37)	6 (13.30)
28	12 (3.32)	10 (5.37)	6 (13.30)	4 (21.29)
30	12 (3.32)	10 (5.37)	6 (13.30)	4 (21.29)