



EXPRESS EXE-MAX **Hydraulic Wrench Pump**



TECHNICAL DATA

TITAN EXPRESS MAX

MOTOR : .56 Kw / .75HP

PUMP :

Type 3 stages
Flow 6.4 l/min from 0 to 1000 psi
1.8 l/min from 1000 to 3000 psi
0.7 l/min from 3000 to 10,000 psi

Max. Pressure 10,000 psi

SIZE :

Length 41 cm / 16.2 in
Width 30 cm / 11.8 in
Height 44 cm / 17.5 in

Weight : 27 kg / 59 lbs

OIL TANK : 1.750 Gallon

OIL : Use only Grade 46 mineral hydraulic oil. Proper hydraulic oil is available from Titan Technologies.
ISO 6743-4 HV NFE 48602 HV



WARNING!!!

- Before operating the pump, make sure all hose connections are tight – use the proper tools to tighten connections.
- Do not overtighten the connections. Connections need only to be tightened securely and leak-free. Overtightening may cause premature thread failure or high pressure fittings to split at pressures lower than their rated capacities.
- Hydraulic line disconnection: fully retract the cylinder and remove any load by releasing the white button on the remote control.
- Should a hydraulic hose ever burst or rupture, immediately shut off the pump. **Never attempt to grasp a leaking hose under pressure with your hands. The force of the escaping hydraulic fluid could cause serious and permanent injury. Check hoses for kinks. Replace kinked hoses .**
- Avoid any condition or conditions which could damage the hose and impair the pump or valve's performance. Never allow the hose to kink, twist, curl or bend so tightly that the oil flow within the hose is blocked or reduce. This could damage the hose and possibly result in serious injury to persons working in the immediate vicinity.
- Do not subject the hose to any potential hazard (ex: fire, extreme heat or cold, heavy impact or sharp surfaces) which might rupture or weaken the hose.
- Periodically inspect the hose for signs of wear. **Never use a defective hose with any pressurized equipment.**
- Never paint the hose or the couplers!
- Hose material and coupler seals must be compatible with the hydraulic fluid used.
- The pump maximum working pressure is 10,000 PSI / 700 bar. Your Titan Technologies Hydraulic Wrenches are also rated at 10,000 PSI as are hydraulic fittings & hoses supplied by Titan.
If using alien equipment, please make sure that all hydraulic equipment such as wrenches, hoses, etc. used with this pump are rated at 10,000 PSI operating pressure.
- **Check for proper electrical supply before connecting.**
- This motor may spark. Do not operate in an explosive atmosphere or in the presence of conductive liquids. If you intend to use your Titan Equipment in an explosive environment, USE ONLY Air/Hydraulic explosion Proof Models. **Never use an electric power pump in explosive environments.**
- Compare motor nameplate against power availability to prevent motor burnout or dangerous electrical overloading.

PREVENTIVE MAINTENANCE – EXPRESS Series Pumps

⚠ WARNING : THE ELECTRICAL POWER CORD MUST BE DISCONNECTED FROM ELECTRICAL OUTLETS BEFORE PERFORMING MAINTENANCE OR REPAIR PROCEDURES.

EXPRESS pumps are precision-built hydraulic units and, as such, do require a certain amount of care and maintenance.

1. **Hydraulic Oil :** oil should be completely changed after every 40 hours of operation, or at least twice a year. Always make sure the reservoir is filled with fluid. If additional oil is required, use only high-grade hydraulic, such as Titan grade 46.
2. **Quick-Disconnects :** Fittings should be checked periodically for leaks. Dirt and foreign materials should be kept away from fittings. Clean before use.
3. **Gauge :** TITAN gauges are liquid filled. Should this liquid level drop, it indicates external leakage, and replacement is necessary. Should the gauge fill with hydraulic oil, it indicates internal failure and should be discarded.
4. **Motor :** The motor shaft and bearings should be flushed and lubricated once a year.
5. **Filter :** The filter should be replaced twice a year for a normal use, and more often if pump is in daily use.
6. **Remote control :** The electric cord or air line to the remote control should be checked for kinks or obstructions periodically. If there is a bend or break in the line, it must be replaced. The spring-loaded buttons on the remote handle should be checked in the event of operating difficulties.
7. **Oil tank :** Should be checked for prevention of leakage.
8. **Pumping unit :** The pump should be overhauled every 2 years. This can be done by TITAN or by a qualified hydraulic service center.

To have a longer life pump, it is better to clean up the pump after use.

OPERATION MANUAL

1. Prior to using the pump :

- 1.1 Check oil level in reservoir.
- 1.2 Check the pump, remote control and hydraulic hose for signs of damage.
- 1.3 Connect the remote control unit.
- 1.4 Connect the twin line hoses and check all system fittings and connections to be sure they are tight and leak free.
- 1.5 Ensure that the torque valve is set to zero by fully rotating it anti-clockwise.
- 1.6 Be sure the electrical connection is grounded. Check that your power agrees with the motor nameplate. Plug power cord into outlet.

2. Operation :

- 2.1 Press and release the white button on the remote control to START THE PUMP.
- 2.2 The tool is pressurised by holding the white button down and pressurised by releasing it.
- 2.3 Press the black button to STOP THE PUMP.
- 2.4 The motor will automatically switch off approximately 1 minute after the last operation on the remote control.
- 2.5 Bleed to the pump to ensure that there air is purged from the system, by opening the torque control valve fully anti-clockwise and with motor running hold the white button down for 15-20 seconds release and repeat.

3. Torque Setting :

- Make these adjustments BEFORE putting torque wrench on nut or bolt head.
- 3.1 See torque wrench chart to have the amount of pressure required to produce desired torque.
 - 3.2 Press and hold the white button to advance the piston.
 - 3.3 While holding the button, slowly turn the pressure valve (clockwise) to increase pressure on the gauge.
 - 3.4 Stop when the required pressure appears on the gauge and release the button.
 - 3.5 Repeat the 3.2 to control that the pressure on the gauge is right.
 - 3.6 If the pressure on the gauge is not good, repeat step 3.2 to 3.5.
 - 3.6 Once the desired pressure has been reached tighten the lock nut on the pressure valve.
 - 3.7 You can put the tool on the nut and run the pump.

3A Operation with the optional Automatic Torque System:

- 3A1 Adjust the requested pressure / torque.
Start the motor by pressing and releasing the white button on the remote control.
- 3A2 Press and hold the blue button. The Automatic Torque System will advance and retract the tool piston until the requested pressure / torque is reached.
- 3A3 If the tool doesn't rotate anymore, release the blue button and press the white button to control that the requested pressure / torque is reached.
- 3A4 Press the black button to stop the motor.

4. After use :

Be sure that there is no pressure in the line:

- 4.1 Switch off the pump using the black button on the remote control.
- 4.2 Turn off the electrical supply.
- 4.3 Disconnect the hydraulic hoses.

It's very important to clean up as often as you can the pump unit.

ELECTRICAL SCHEME

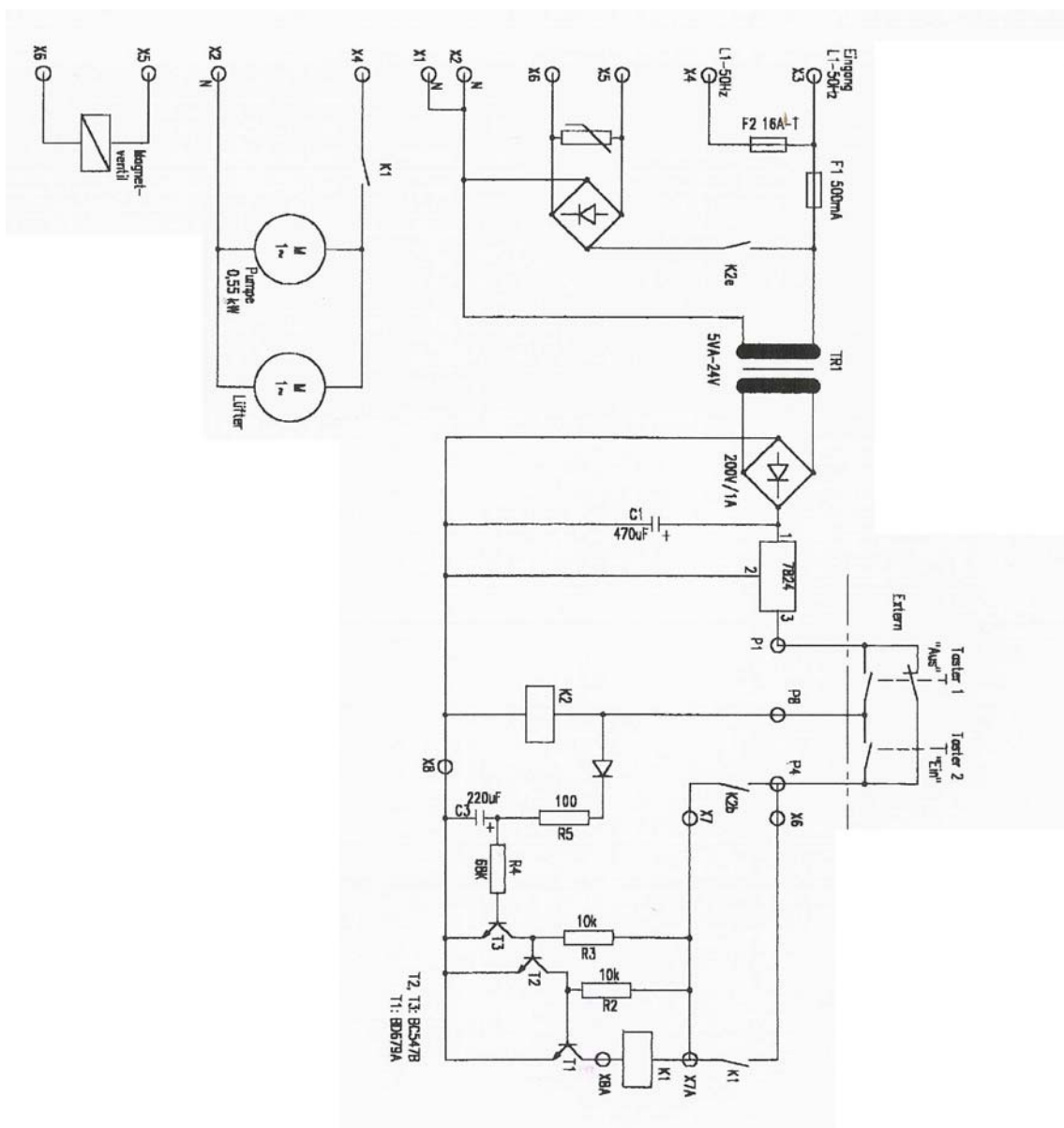

HYDRAULIC SCHEME

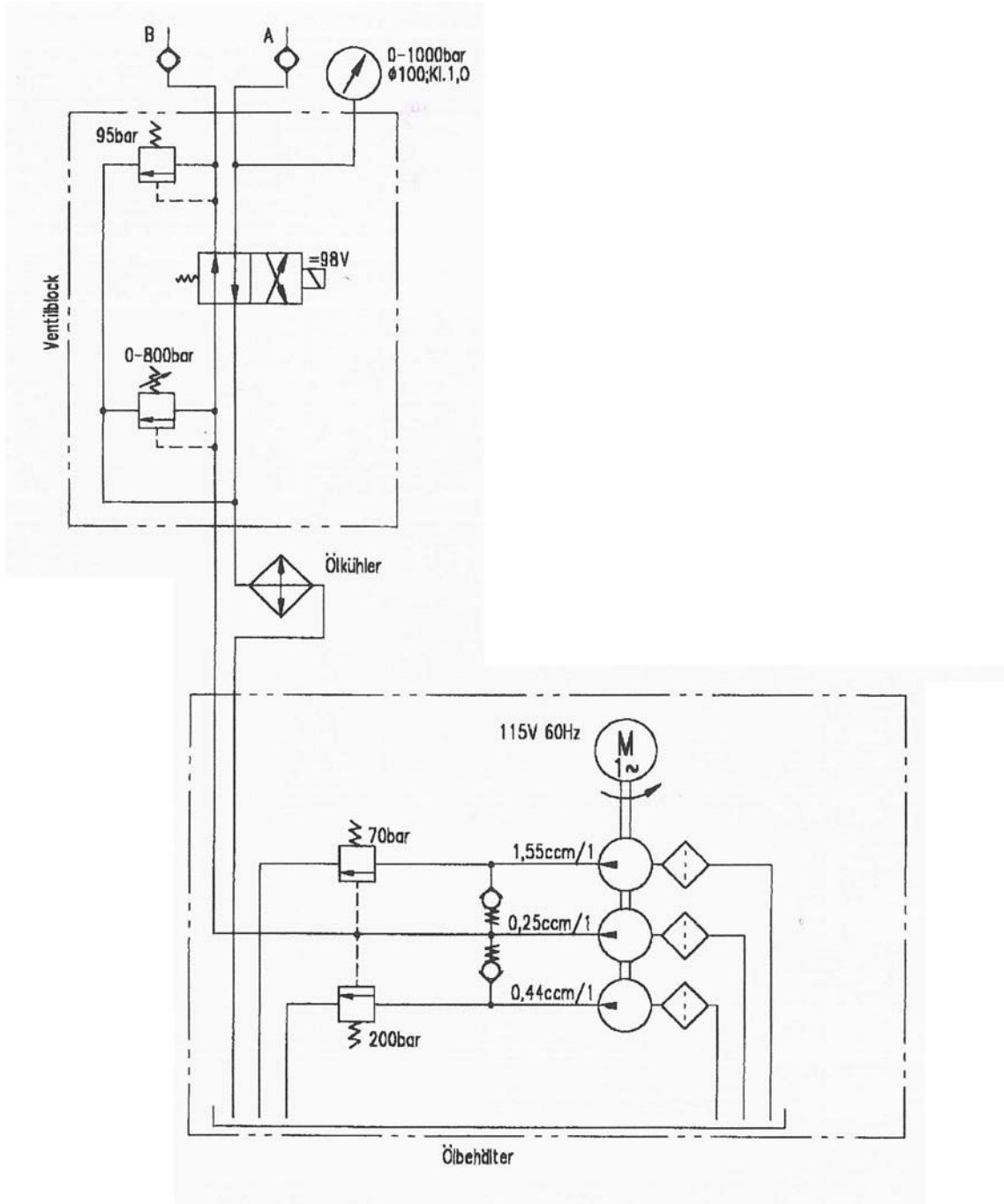

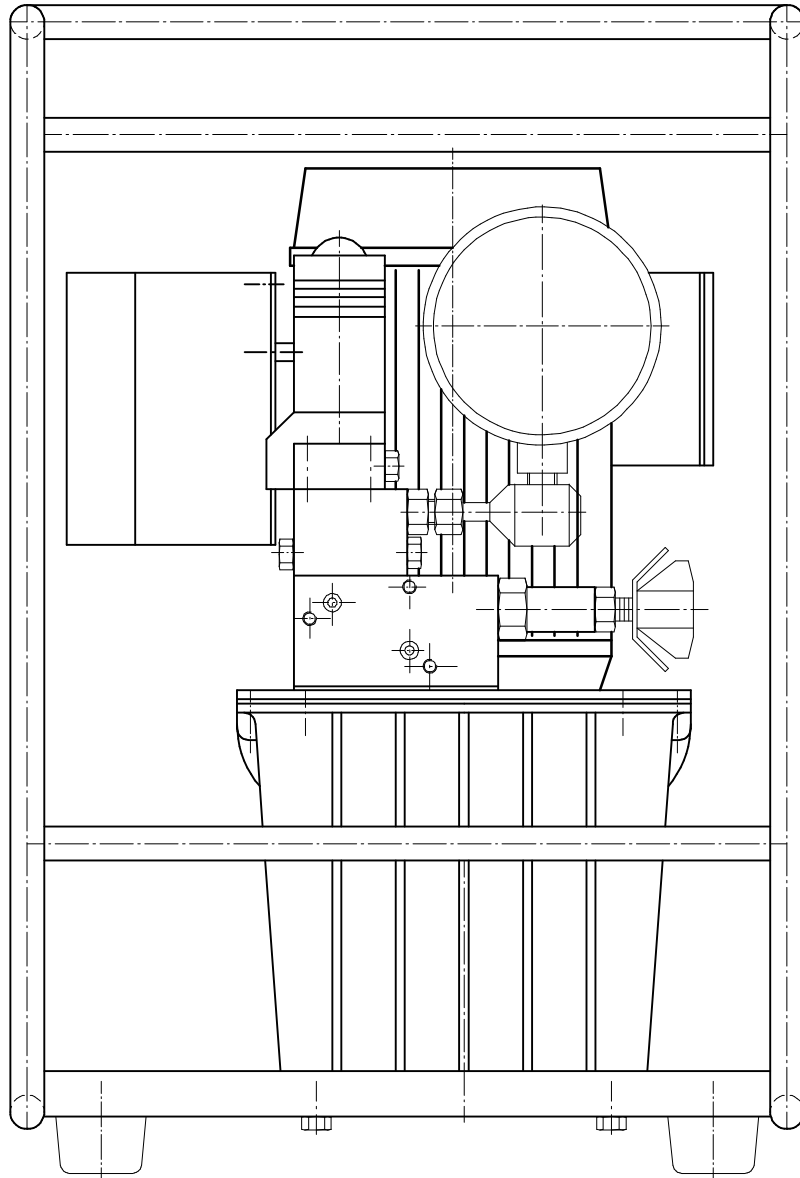

Hydraulic pump Express Max

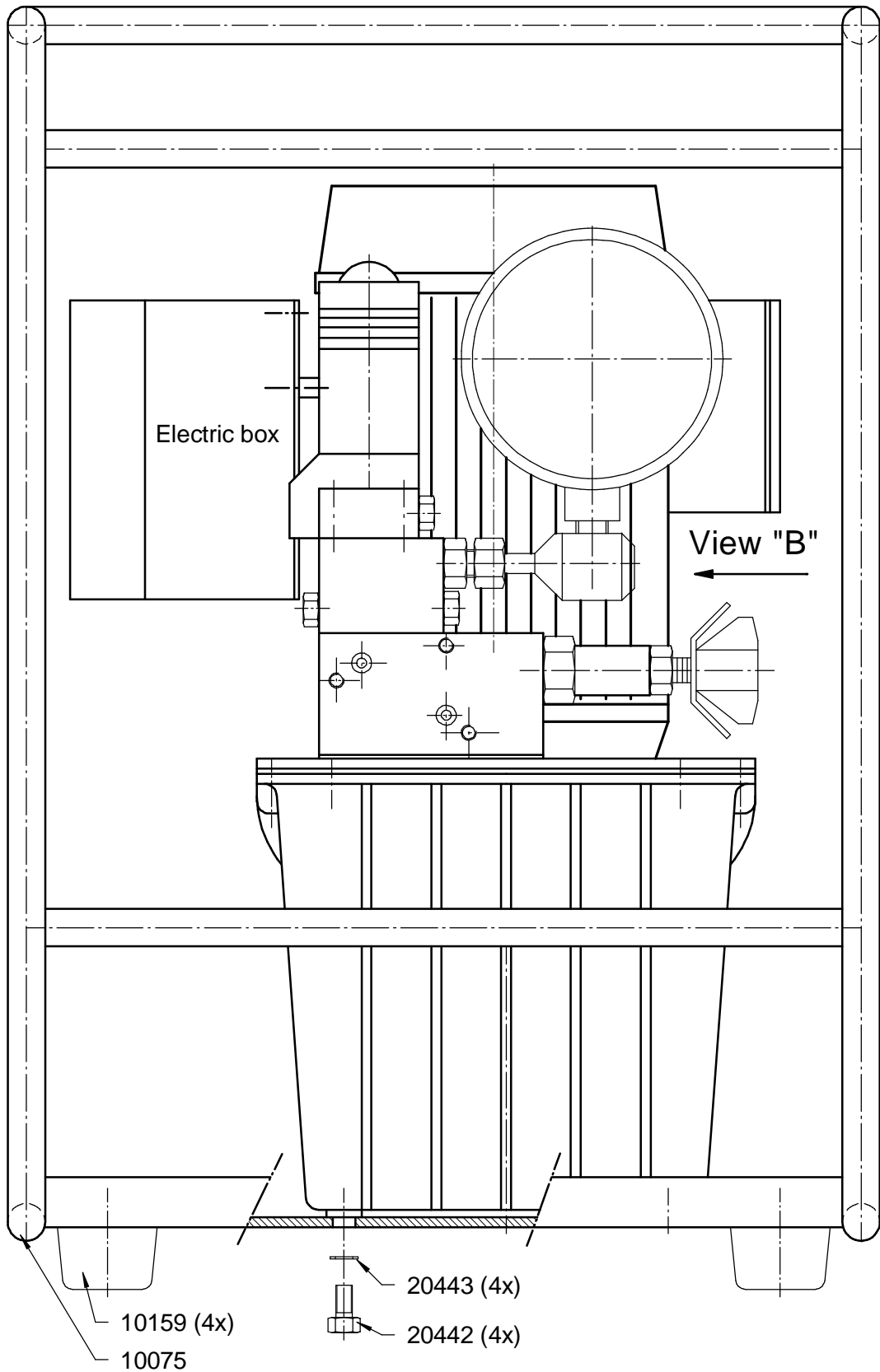

Hydraulic pump Express Max "View "B"

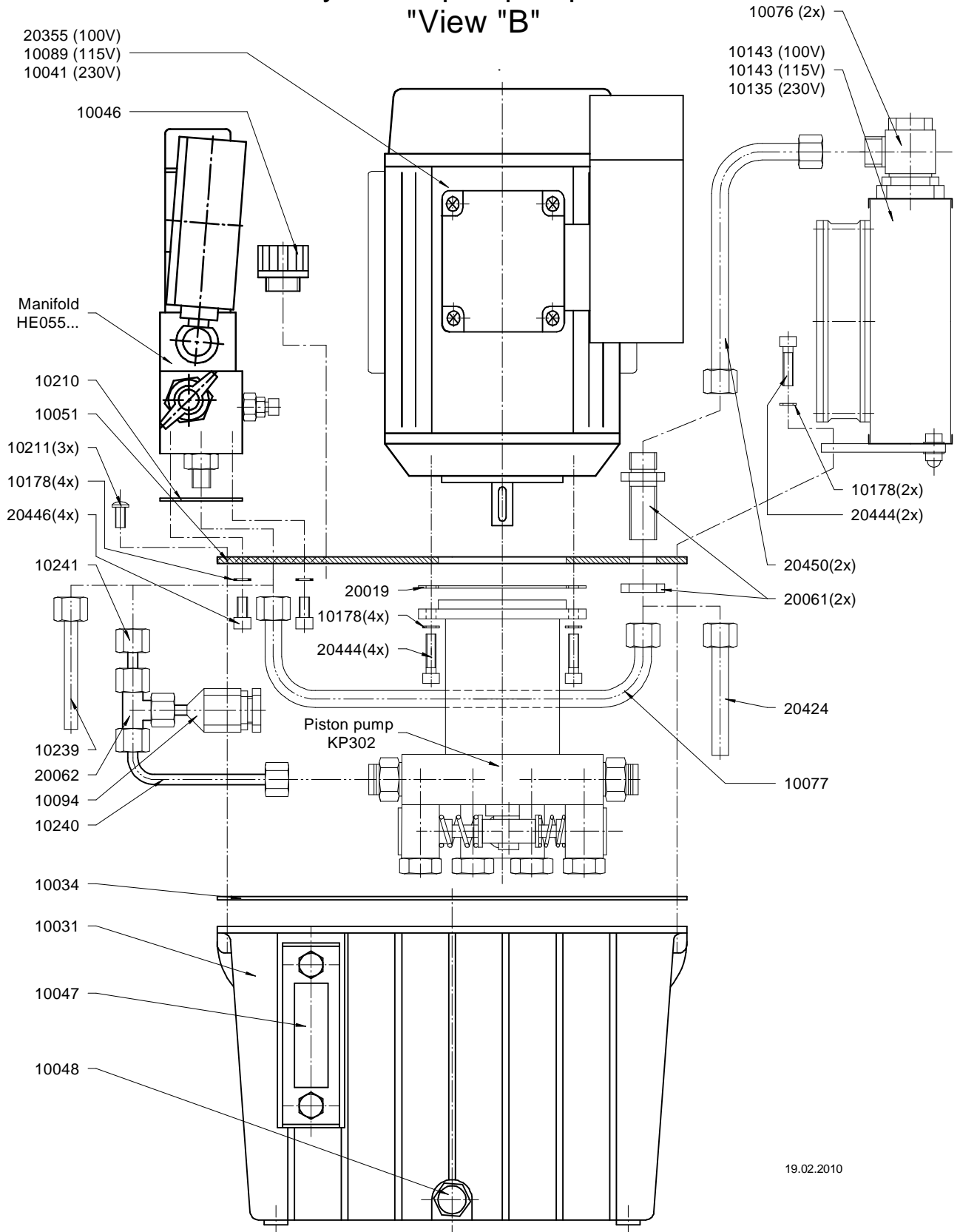

Electric box Express Max

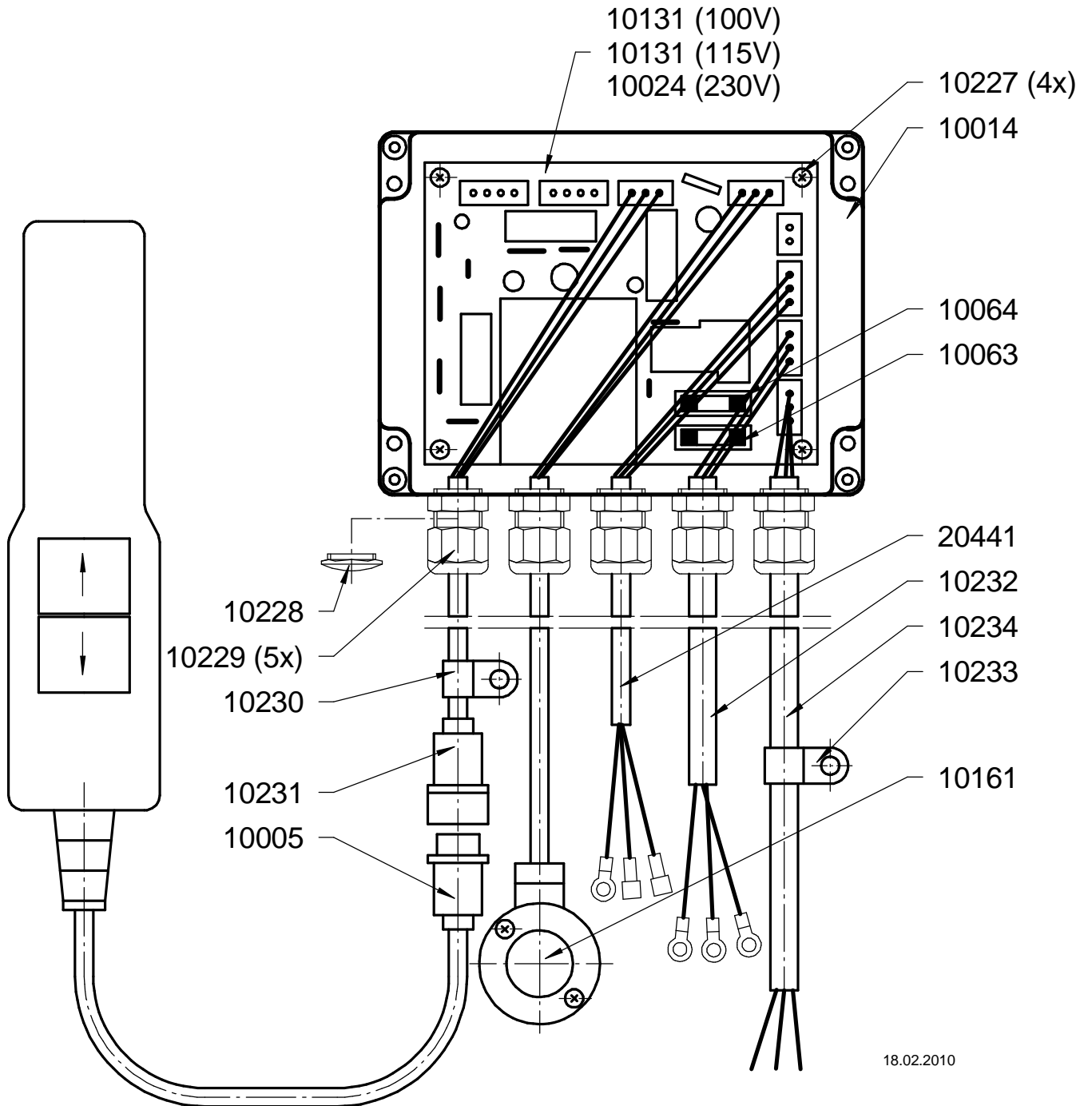

Manifold Express Max

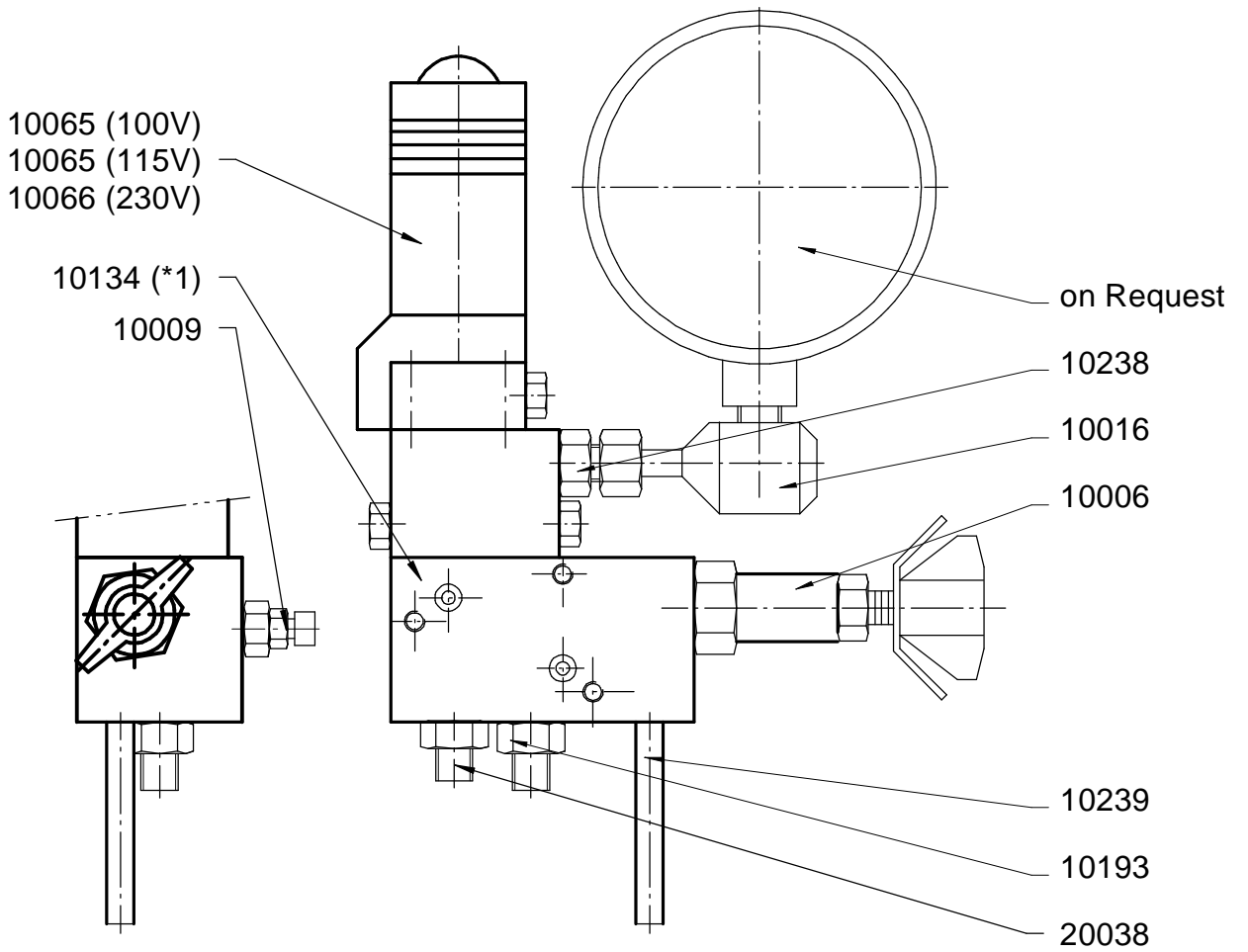

*1 : For direct Coupler connection use 10082

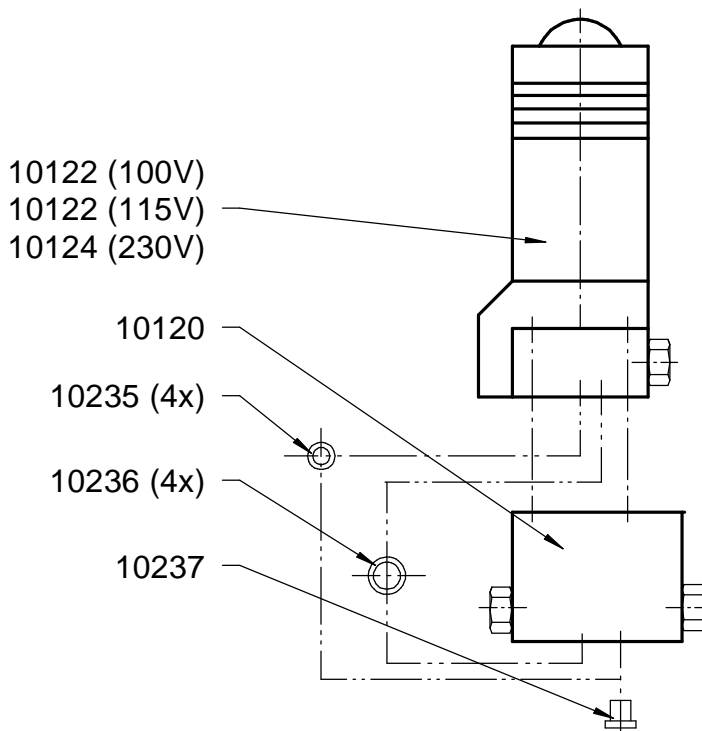

Piston pump

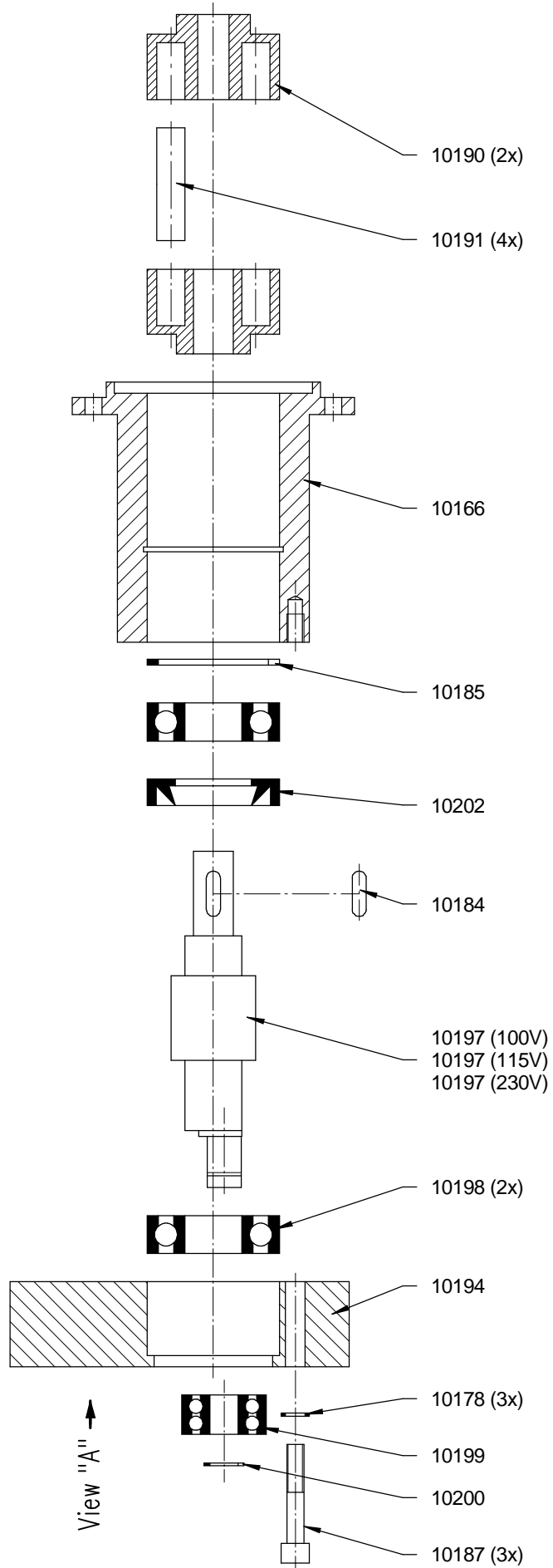

Piston pump View "A"

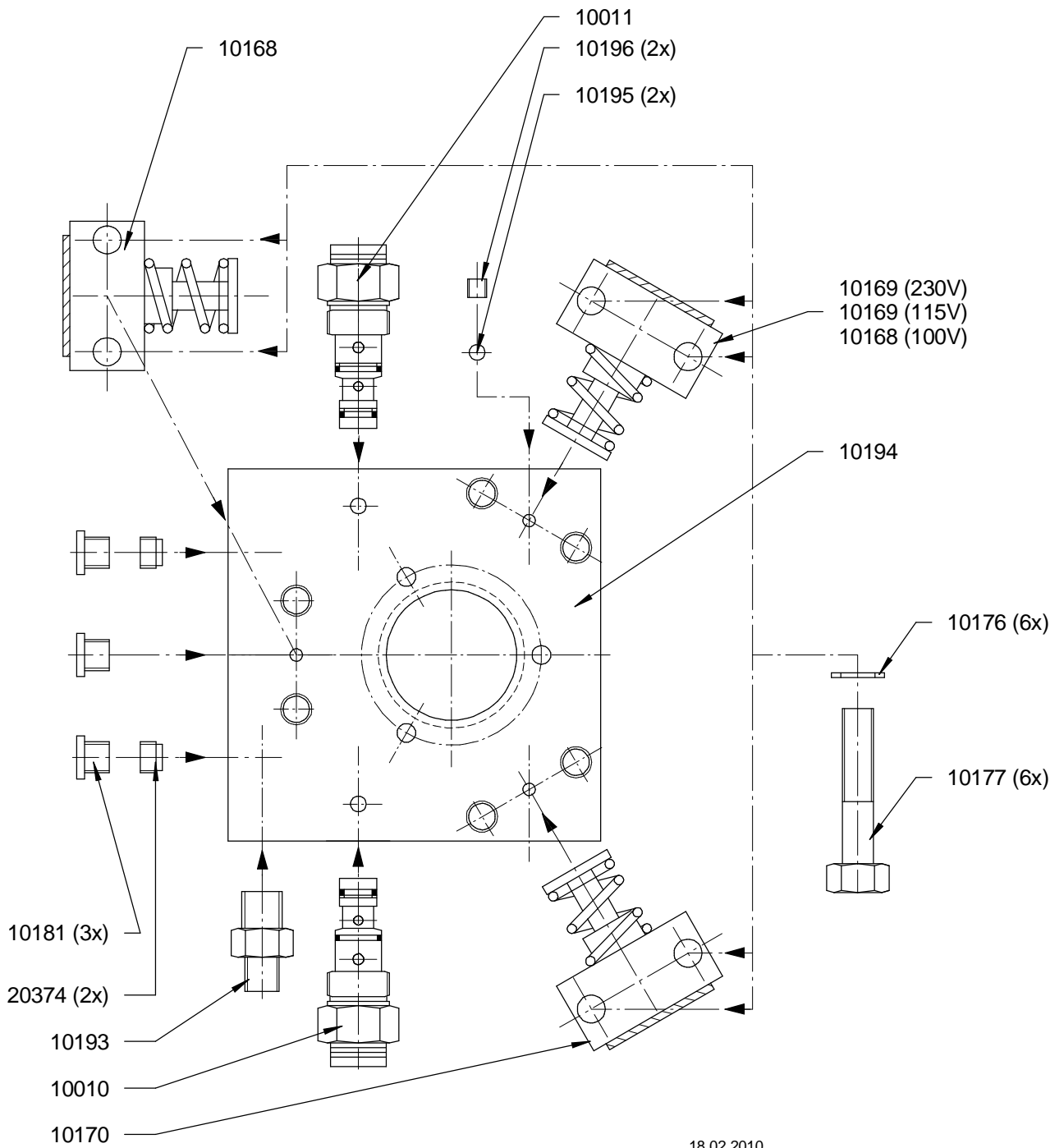

Electric Motors

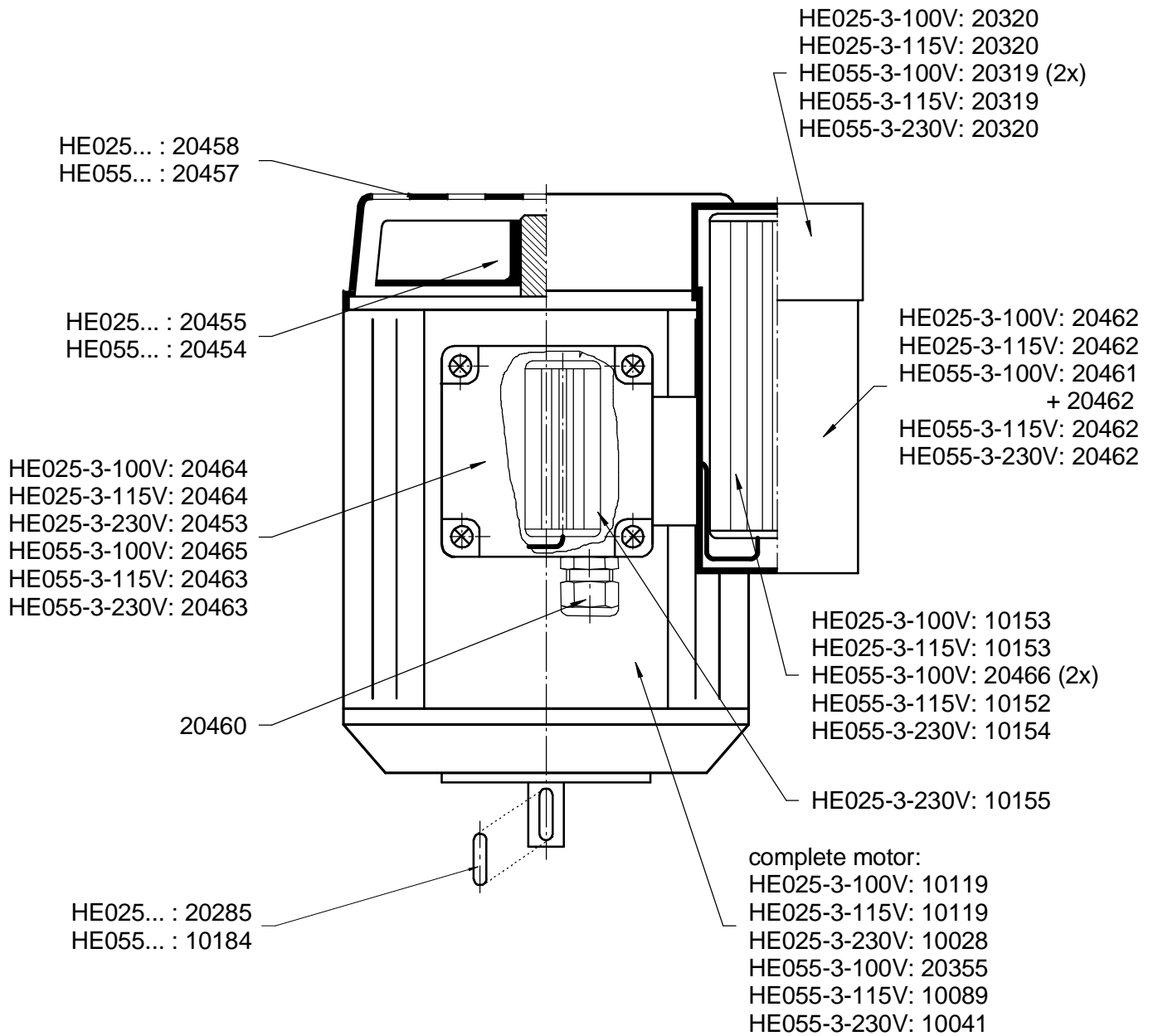

TITAN EXPRESS EXE-MAX PARTS LIST

Part #	Description	Part #	Description
10001	Hydraulic fluid ISO VG 46	10090	120x120; 115V / Fan
10003	0-700bar/10.000PSI / Gauge	10091	HE 055-115V / Electrical control
10004	0-1000bar / Gauge	10093	Wear set KP305
10005	FB el. 5m / remote control	10094	750 bar / Safety valve
10006	Pressure setting valve MVE 4 AR-700	10095	Oil Filter OC90
10008	RVA4 / Check valve	10097	Wear set KP303
10009	Back pressure valve DBV4-100	10098	Cooling tank
10010	AV 75 / Shut-off Valve	10100	Wear set KP202
10011	AV 250 / Shut-off Valve	10102	Wear set KP302/50
10013	302/50 / pump shaft	10104	Wear set KP302/60
10014	T2381 / Control Box	10106	Wear set KP301
10015	AC protector BC 6-30-10/1,4	10111	Seal-Kit HE025
10016	1/4"NPT - 8SR / Gauge connector	10112	Seal-Kit HE055
10017	Magnetic valve adapter incl. Rectifier male	10113	Seal-Kit HE150
10018	Heat sink 119-50-M16x1,5	10114	Seal-Kit HP110
10019	120x120; 230V / Fan	10115	Seal-Kit HP280
10020	seat valve WG 3-1-G 205 *	10118	Electric control HE 025-100-120V
10021	V4M / Air motor	10119	63G115 / Electric motor
10022	seat valve WG 4-1-G 205 *	10120	Seat Valve G/P 4-1 (Lower)
10024	1~230V 50Hz / electric Board	10121	Motor shaft ECS63
10026	Elastic shaft coupling	10122	Seat Valve G 3-1-G 98 (~115V)
10027	Maintenance unit G1/4" 0,5-10bar w/gauge	10123	Seat Valve P 3-1 (air control)
10028	63G230 / Electric motor	10124	Seat Valve G 3-1-G 205 (~230V)
10029	Remote Control	10125	x4-2xx / Seat Valve Seal kit
10030	Alum. Tank CP3 w/Oil sight glass, Thermometer, screw	10126	80G115 / electric motor
10031	Alum. Tank CP6 w/Oil sight glass, Thermometer, screw	10127	Motor Valve
10032	Alum.Tank CP10 w/Oil sight glass, Thermometer, screw	10128	RVB4 / Check valve
10033	Container sealing GCP 3	10129	MPE5 / piston
10034	Container sealing GCP 6	10130	MPE8 / piston
10035	Container sealing GCP 10	10131	1~100-120V 50+60Hz / electric Board
10036	Coupling connector NG6-700bar-1/4"NPT-IG	10132	PE13 / piston
10038	0-10bar / Gauge	10133	Check valve assembly tool RVA4
10039	DN 1/4"NPT / Double socket	10134	Valve block MIV
10040	G1/2" 0,5-10bar w/Gauge / Complete Unit with Gauge	10135	Oil cooler 119-50-M16x1,5-230V
10041	71G230 / Electric motor	10137	ø4 - Y-connector
10042	6 AM / Air motor	10138	1/8"/4 - L-connector
10045	HE 025 / small Frame	10139	1/4"/4 - L-connector
10046	Filler bolt with filter	10143	Oil cooler 119-50-M16x1,5-110-120V
10047	Oil sight glass incl. Thermometer	10144	1/4"NPT - 1/4"NPT / Gauge connector
10048	1/4" / Oil drain screw	10145	4200 / ball bearing
10049	3/8" / Oil drain screw	10146	Screw G1/8" DIN 908
10050	HE 025 / Container lid	10147	10x14x1 Cu / Sealing ring
10051	HE 055 / Container lid	10148	301 / pump body
10052	HP 110 / Container lid	10149	301 / Shut-off Block
10053	HP 280 / Container lid	10150	301 / housing
10054	HE 150 / Container lid	10152	Capicitor 60uF/220V
10058	HE 025-230V / Electrical control	10153	Capicitor 40uF/220V
10059	055-230V / Electrical control	10154	Capicitor 20uF/450V
10060	HE 150-230V / Electrical control	10155	Capicitor 12uF/450V
10061	DN 1/4"NPT / Double nipple	10159	Rubber feet with screws
10063	M 0,5A 250V / Fuse	10161	Solenoid adapter with cable
10064	T 16A 250V / Fuse	10163	Hex Plug 1/8"
10065	Seat Valve G 4-1-R-G 98 (Complete)	10164	303/305 / pump body
10066	Seat Valve G 4-1-R-G 205 (Complete)	10165	Motor shaft ECS71
10067	Seat Valve P 4-1-R (Complete)	10166	302 housing
10074	63-71-80 / Protective cover	10168	PE6 / piston
10075	HE055 / full Frame	10169	PE8 / piston
10076	Fitting WH 10 - S (M16x1,5) w/Edge seal	10170	PE15 / piston
10077	Radiator pipe inside HE055	10171	ø4 / V-connector
10078	MIK valve block	10174	cover 63 - 80
10079	1/4" / muffler	10176	DIN127-B10 044010 / spring ring 10
10080	HP110 / small Frame	10177	DIN931-M10x50-8.8 / Screw
10081	5m / Remote Control	10178	DIN7980-B6 / spring ring 6
10082	MI valve block	10179	DIN912-M6x30-8.8 / Screw
10083	Motor Valve 1/4"	10180	301 / pump shaft
10084	1/2" / muffler	10181	G1/8"-ED / screw
10085	HP280 / full Frame	10182	6202.2Z / ball bearing
10086	Motor Valve 1/2"	10183	20x35x7 BA / Seal
10087	WE / fixing bracket	10184	5x5x16 / key
10088	FB / fixing bracket	10185	DIN 471-A10 / ring
10089	71G115 / Electric motor	10186	DIN912-M6x45-8.8 / Screw

TITAN EXPRESS EXE-MAX PARTS LIST (continued)

Part #	Description	Part #	Description
10187	DIN912-M6x40-8.8 / Screw	20018	63 - Z10020
10188	O-Ring 6x1,5-90 NBR	20019	71 - Z10027
10189	DIN 472-I35 / ring	20020	80 - Zxxxxx
10190	ø14 / coupler	20021	6AM - Seal
10191	ø10x40 St / bolt	20022	FB - Z10090
10192	ø11 / coupler	20023	MI - Zxxxxx
10193	GE6SR / fitting	20024	KA - Zxxxxx
10194	302 / pump body	20025	MA - Zxxxxx
10195	ø5 / steel ball	20026	MV - Zxxxxx
10196	913-M6x6 / screw	20029	WE 8 - LLR
10197	302/60 / pump shaft	20032	WE 12 - LR
10198	6204.2Z / ball bearing	20038	GE 10 - LLR
10199	4201 / ball bearing	20042	Adapter M16 PL
10200	DIN 471-A12 / ring	20053	1/2" / Oil drain screw
10201	DIN 472-I47 / ring	20055	308 / pump shaft
10202	30x47x7 BA / Seal	20058	119PL
10203	303 / pump shaft	20060	GE 10 - L 1/4" NPT
10204	305 / pump shaft	20061	SV 10 - L
10205	6203.2Z / ball bearing	20062	T 6 - S / T-Fitting
10206	DIN 472-I40 / ring	20063	T 8 - LL
10209	manifold MI 100V compl.	20064	Verschlußschraube VSTI R1/8" ED
10210	MI / Seal	20065	EVGE 10 - LR ED
10211	M6x16-10.9 / screw	20071	GE 6 - LLR
10213	DIN 912 M6x16-8.8 / screw	20073	GE 8 - LLR
10214	NG 63 / Seal	20074	GE 8 - LR
10215	DIN 127-B5 / washer	20075	GE 8 - SR
10216	DIN 931 M5x20-8.8 / screw	20077	WE 10 - LR
10218	DIN 934-M4 / nut	20081	Dbl Nipple G 1/4" AG x 1/4 NPT" AG verz. SW19
10219	HE025 / angle iron	20084	GE 12 - PL 1/2" NPT
10220	DIN 912 M4x14-8.8 / screw	20114	M20x1,5 / fastener screw
10221	DIN 931 M6x20-8.8 / screw	20115	High pres. adapter G 1/4" - G1/4"
10222	DIN 125-M6 / washer	20119	MPE9 / piston
10223	DIN 912 M6x30-8.8 / screw	20121	PE12 / piston
10224	HE025-1 / pipe	20130	2-way nipple 1/4"NPTAG verz.
10225	T6-S / fitting	20133	connector 115 NPT 1/4" IG
10226	HE025-2 / pipe	20134	connector 116 G 1/4" IG
10227	4,5x7 / screw	20135	connector 125 G 1/4" IG
10228	M16x1,5 / fastener screw	20136	connector 230 NPT 1/4"
10229	M16x1,5 / cable screw	20138	connector 115 NPT 1/4" IG
10230	ø6 / clamp	20139	connector 116 G 1/4" IG
10231	Remote w/ cable	20140	connector 125 G 1/4" IG
10232	HE055 / motor cable	20141	connector 230 NPT 1/4"
10233	ø9 / clamp	20142	SOFTEX - coupling 24/30.19-14 Alu
10234	main supply cable	20143	25x42x7 BA / Seal
10235	5x1,5-90 NBR / o-ring	20144	20x40x7 BA / Seal
10236	9x1,5-90 NBR / o-ring	20146	9x / Minibooster
10237	RE1 / Check valve	20147	EMB-Screw SHEO M18x1,5
10238	GE8-SR / fitting	20153	DIN 7980-B5 / Spring ring 5
10239	ø8 x 110 / pipe	20154	80K230 / electric motor
10240	HE055-1 / pipe	20157	solenoid 230V AG
10241	HE055-2 / pipe	20158	solenoid 115V AG
10243	housing 303	20160	Stainless Steel 1/2"
10244	housing 305	20161	closure 1/2"x25
10300	G1/4" / rubber-metal seal	20162	Fitting Typ 3280 1/2" axa
10301	FB HD 5m / Remote Control Assy	20163	FittingDVGW Typ 3540 1/2" x2500 (I/A)
10302	HD 230V / Circuit Board	20164	Fitting90° Typ 3092 1/2" ixa
10303	HD 115V / Circuit Board	20165	FittingTyp 3531 1/2"
10304	0-2500bar/35.000PSI gauge w/certificate	20166	Valve, NC, Art.Nr.511.131
10306	HP220 / full Frame	20167	Filler KE 1
20001	Spacer 14x18x1,5 cu	20174	4202 / ball bearing
20002	Clamp 13/15	20175	6004 / ball bearing
20003	Fitting 1/2" - G1/4"	20176	6301 / ball bearing
20004	Clamp 20/23	20177	6305 / ball bearing
20006	Valve Assembly G 4-1-R-G 24 (complete)	20178	Sleeve NG6-700bar 1/4"NPTAG
20010	MPE6 / piston	20182	Filter UFR 04
20011	MPE7 / piston	20183	Guage ø100 KI.1.0 0-2000bar C
20012	PE7 / piston	20184	Guage ø100 KI.1.0 0-1000bar C
20013	PE10 / piston	20185	Condenser 60 uF/220V
20014	PE14 / piston	20186	4/3 Valve 230V
20015	PE16 / piston	20187	4/3 Valve 115V
20016	Remote Control / Male-plug-in	20221	Meter-632.2

TITAN EXPRESS EXE-MAX PARTS LIST (continued)

Part #	Description	Part #	Description
20234	T238 / Control Box	20435	Fitting 12mm" - G1/4"
20236	Thermostat 40°C	20438	DIN 7991 M8x12 8.8 galvanized
20248	Guage 0-10bar; ø40-G1/8"	20440	DIN 7991 M6x12 8.8 galvanized
20252	Guage G1/4 ø50 0-16bar	20441	Cooler supply cable
20254	Motor Condenser / Capicitor 120uF/330V	20442	DIN 933-M8x16-8.8 galv.
20256	80K115 / electric motor	20443	DIN 127-B8 / washer
20257	Sleeve 3050-2 1/4" NPT	20444	Cylinder screw DIN 912-M6x25-8.8 galv.
20258	Sleeve 3010-2 1/4" NPT	20445	Cylinder screw DIN 912-M6x40-8.8 galv.
20259	Poppet valve SV08	20446	Cylinder screw DIN 912-M6x16-8.8 galv.
20261	3/2-valve M/20134/40	20447	Cylinder screw DIN 912-M6x12-8.8 galv.
20262	3/2-valve M/20132/40	20448	Cylinder screw DIN 912-M6x30-8.8 galv..
20263	Plug NG6-700bar 1/4"NPT IG	20449	Cylinder screw DIN 912-M6x90-8.8 galv.
20267	O-Ring 12,37x2,62 NBR 90 / o-ring	20450	Cooler pipe outside HE055
20268	O-Ring 12x1,5 - N 9002	20451	HE025 / motor cable
20269	O-Ring 10x2 - 70 NBR	20453	Typ1 / small electrical box
20270	O-Ring 9x3 -70 NBR	20454	Fan 71
20271	Nipple G1/2" AG - G1/4" IG SW22	20455	Fan 63
20274	201 / housing	20456	Fan 80
20275	O-Ring 2x1,5-90 NBR / o-ring	20457	Fan shroud S 71
20282	Hex G 3/8"	20458	Fan shroud S 63
20283	ø12 / clamp	20459	Fan shroud S 80
20284	ø8 / clamp	20460	M20x1,5 / cable screw
20285	4x4x16 / key	20461	Capicitor housing left
20306	Connector w/ cable	20462	Capicitor housing right
20307	HE025 / full Frame	20463	Typ2 / small electrical box
20308	GN 552-31-G1/2"-A-2 mit PU-Filter	20464	Typ3 / small electrical box
20309	GN 747-G3/8-B-1	20465	Typ4 / small electrical box
20310	GN 552-31-G3/8-A-2 w/PU-Filter	20466	Capicitor 50uF/220V
20311	HP110 / full Frame	20467	Capicitor 40uF/450V
20312	HDE 1600 / Container lid	20468	6x6x25 / key
20313	HP300 / full Frame	20475	Piston for engine valve
20314	HP 300 / Container lid	20476	Housing for the engine valve
20315	HEC 110 / Container lid	20477	O-Ring 17x1,5 - 70 NBR
20319	Condenser	20515	SDIN 9021 m12 ø13 / Plain washer
20320	Condenser	20520	Capicitor 30uF/450V
20326	120x120; 24V / Fan	20521	Repair Kit V4M
20328	80G230 / electric motor	20523	Repair Kit 6AM
20331	Oil sight glass	20527	Repair Kit for HP300 including: 10006 - MVE 4 AR / Pressure Regulating Valve 20374 - RK0 (2x) / Check Valve 10010 - AV75 / Cut off Valve 10011 - AV250 / Cut off Valve 10038 - ø60 10bar / Gauge 20257 - Parker 3050 / Coupling 20258 - Parker 3010 / Coupling 20442 - (4x) / Screw 20443 - 4x) / Washer 10072 - Seal Kit for HP280/300
20333	71G400 / electric motor	20529	T217 / Control Box
20334	Hex G 1/8"	20539	Gauge ø63 1000bar
20336	1/8" -4	20540	EGE 8 SR-ED
20337	1/4" -4	20541	EW 8 S
20338	switch T23B	20570	KP310 / piston pump
20355	71G95 / Electric motor	20571	310/50 / pump shaft
20359	HE 055 / small Frame	20572	310/60 / pump shaft
20363	T206 / Control Box	20573	310 / pump body
20364	T206	20574	310 / housing
20373	RVA6 / Check valve	20576	Thermo switch cable
20374	RK0 / Check valve	20580	FE055-1 / pipe
20375	Mounting Tool for Check valve RK0	20581	FE055-2 / pipe
20379	Block HDE1600	20582	FE055-3 / pipe
20380	6mm / rubber-metal seal	20583	Oil cooler 119-50-M16x1,5-24V
20381	Cable 3x1,5mm ² orange	20586	Oil Tank FE055 (incl. cover)
20382	Cable 3x0,75mm ² orange	20588	FE055 / full Frame
20411	2x 1/4"NPT - 8SR / Gauge connector	20590	FE055 / small Frame
20413	Fitting 1/2"	20591	DIN 7380-M6x20 verz.
20414	1/2"	20592	DIN 963-M6x8-8.8 verz. / screw
20415	3/4"	20593	DIN 912-M10x20-8.8 verz. / screw
20416	Hex G 1/4"	20594	DIN7980-B10 / spring ring 10
20417	O-Ring 14x4 - 70 NBR	20595	clamp
20418	Pressure relief valve MVE4 E	R20005	5m / remote control
20419	2-Way Valve		
20420	4x / Minibooster		
20421	O-Ring 18x4 - 70 NBR		
20423	Key 6AM		
20424	ø10 x 60 / pipe		
20427	GE 10 - L M 16x1,5		
20428	1/2"x50		
20429	O-Ring 17x3 - 70 NBR		
20432	Filter UFR 02		
20433	80G400 / electric motor		
20434	Key AB136		

TROUBLE SHOOTING GUIDE

<u>Problem</u>	<u>Probable cause</u>	<u>Solution</u>
Motor runs but no reaction with the tool	<ol style="list-style-type: none"> 1.Quick connect not mated properly. 2.Damaged Connect 3.No or too little oil in reservoir 4.Pressure regulator valve too slow 5.Defective remote control hose 	<ol style="list-style-type: none"> 1.Tighten connection until fully secure. 2.Replace. 3.Control and fill up oil level. 4.Increase. 5.replace.
Tool will not retract	<ol style="list-style-type: none"> 1.same as above 	<ol style="list-style-type: none"> 1.Same as above
Tool cannot be removed	<ol style="list-style-type: none"> 1.Holding Reaction Pawl is engaged. 2.Cylinder did not retract 	<ol style="list-style-type: none"> 1.Pressurize the tool and while keeping the button depressed on the remote control, GENTLY pull back the pawl release lever on the side of the tool. Release the button on the remote & let the piston retract. 2.Check quick connect as described above.
Tool leaks oil	<ol style="list-style-type: none"> 1.Seal damage in cylinder 2.Seal damage in Tru-Swivel 	<ol style="list-style-type: none"> 1.Replace seal. 2.Replace seal.
Tool advance in "retract" Mode or "Visa Versa"	<ol style="list-style-type: none"> 1.Quick connects installed in improper sequence. 	<ol style="list-style-type: none"> 1.Make sure connects are set up in the right way.
Ratchet returns on retract Stroke.	<ol style="list-style-type: none"> 1.Missing, defective or broken Reaction Pawl 	<ol style="list-style-type: none"> 1.Change pawl spring or Reaction Pawl.
Tool will not take successive Strokes	<ol style="list-style-type: none"> 1.Lose or defective quick connect. 2.Operator is depressing advance before oil has a chance to fully return to the reservoir, thus preventing the piston from fully returning before taking the new stroke. 3.Defective Drive Pawl spring 4.Broken Drive Pawl 	<ol style="list-style-type: none"> 1.Fully tighten or replace connects on retract side. 2.Wait for oil to return and for the cylinder to retract completely before taking the next stroke. 3.Replace the spring. 4.Replace.
Motor doesn't run	<ol style="list-style-type: none"> 1.no source 2.Pump starved for air 3.Inedequate power supply 4.Defective remote control hose 	<ol style="list-style-type: none"> 1.Connect air line. 2.Use minimum 1" dia. Air hose, Need 50 cfm. 100psi 6bar air source. 3.Use proper power source. 4.replace remote control.

Air pump Sluggish	<ol style="list-style-type: none"> 1.Pump starved for air 2.Dirt in air motor 3.Dirty Oil Filter 	<ol style="list-style-type: none"> 1.Use minimum1"dia. Air hose, Need 50 cfm.100psi 6bar air source. 2.Flush motor with solvent, clean, dry and lubricate. 3.Clean or replace.
Air motor frozen	<ol style="list-style-type: none"> 1.FLR missing or broken 2.Rotor bearings frozen 3. Obstruction in air valve 4.Improperly installed remote control hoses 5.defective remote control hoses 6.Defective remote button 	<ol style="list-style-type: none"> 1.replace FLR. 2.Inspect & replace. 3.Inspect & clean. 4.Ensure 3-hose system is connected properly.(color coded) 5.Replace. 6.Replace spring.
Pump will not build pressure	<ol style="list-style-type: none"> 1.Inadequate power supply 2.Pump starved for air 3.Defective pressure regulator valve 4.Defective gauge 5.Dirty oil 6.Clogged FRL 	<ol style="list-style-type: none"> 1.Use proper power source. 2.Use minimum1"dia. Air hose, Need 50 cfm.100psi 6bar air source. 3.Replace. 4.Replace. 5.Clean reservoir and replace oil. 6.Replace FLR.
Drop oiler doesn't work	<ol style="list-style-type: none"> 1.No or too little oil in reservoir 2.Drop oiler misplaced 	<ol style="list-style-type: none"> 1.Control and fill up oil level. 2.Adjust to 5-6 drops/min
No pressure reading on gauge	<ol style="list-style-type: none"> 1.Defective gauge 2.Loose connect 3.defective seals 4.Defective motor coupling. 	<ol style="list-style-type: none"> 1.Replace gauge. 2.Tighten connect. 3.Inspect all seals and replace any defective one. 4.replace motor coupling.

Please contact Titan Technologies
or your local Titan Representative or Dealer:



9001 Jameel Street Suite 180 • Houston, TX 77040
Toll-Free: 866.345.8484 • Phone: 281.449.9994 • Fax: 281.449.9996
Email: sales@titanti.com • <http://www.titanti.com>