

FOR INTERNAL USE ONLY

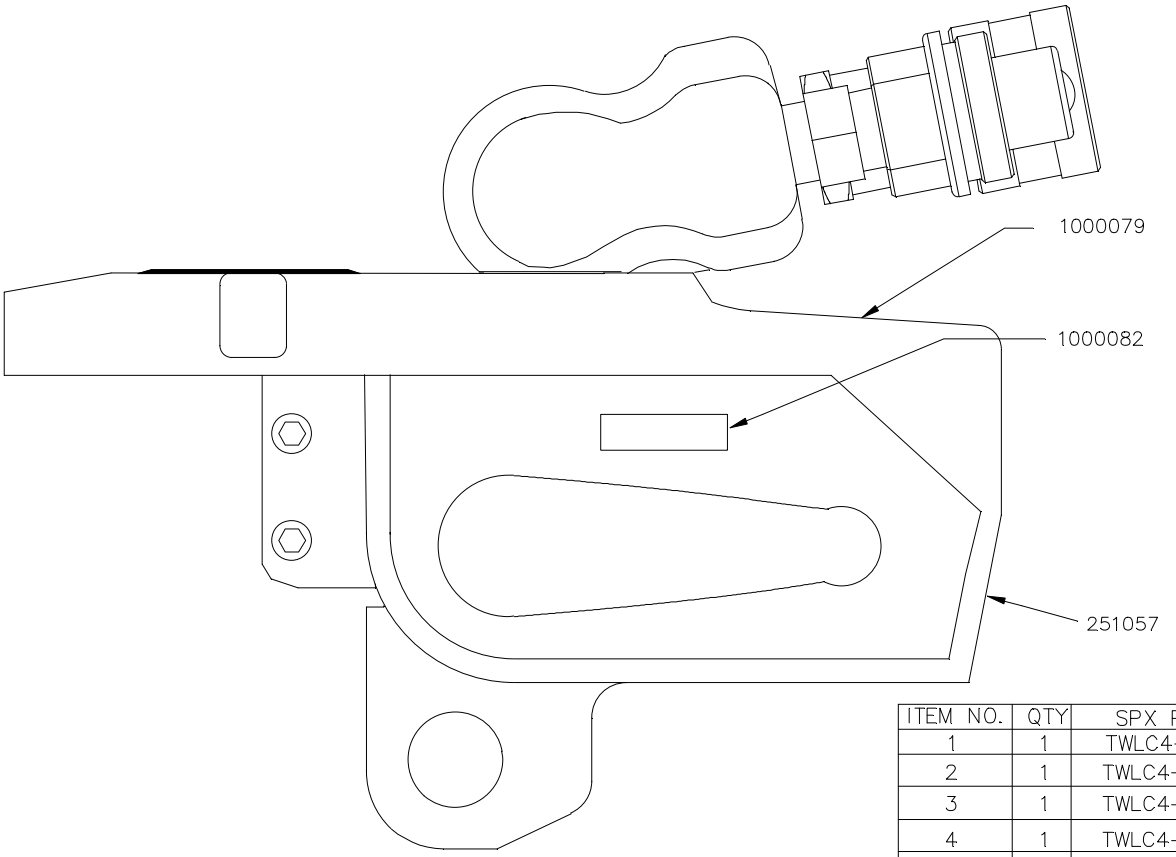
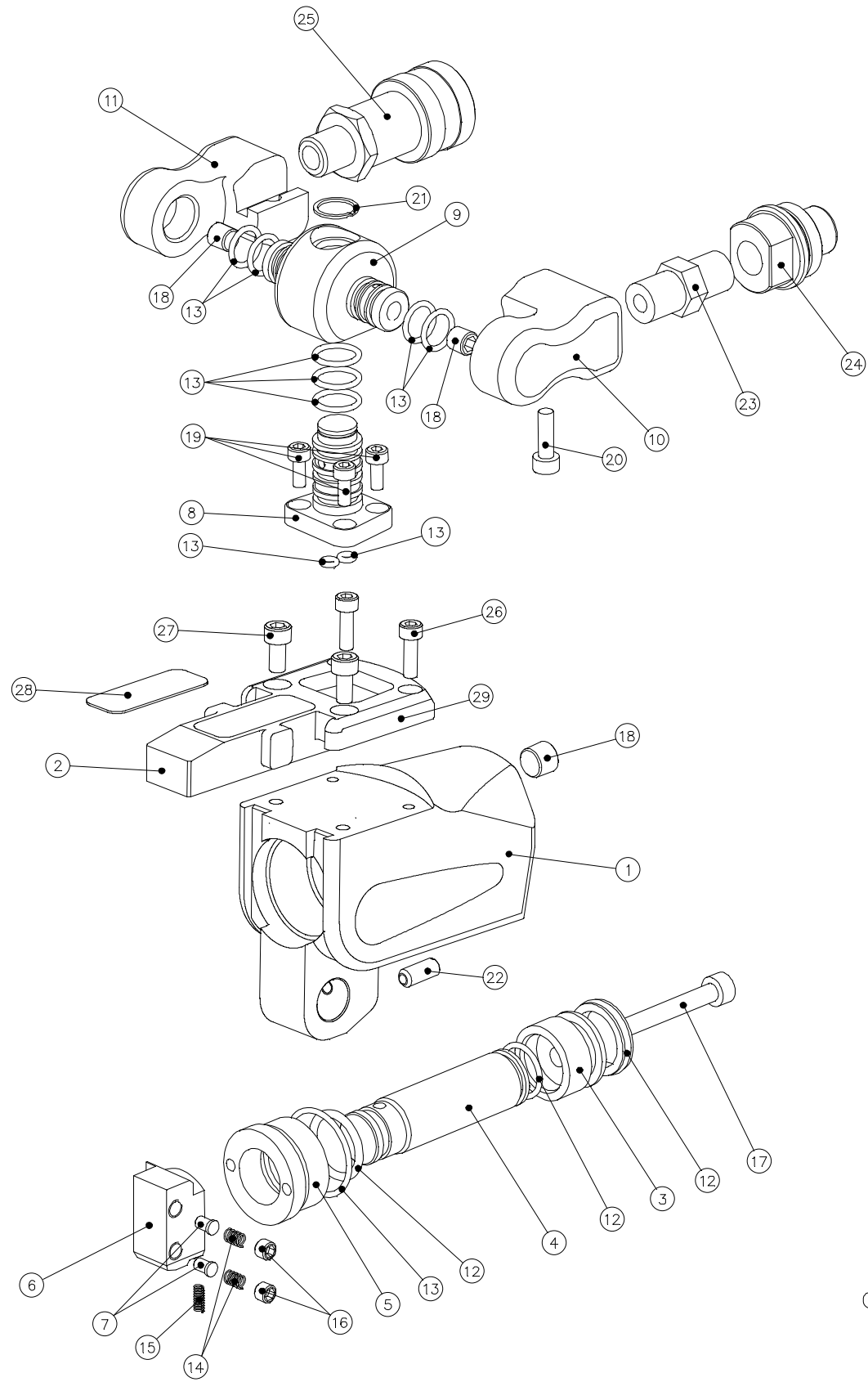

1. ALL WRENCHES TO BE DATE CODED PER SUPPLIER'S STANDARD PROCEDURE.
2. APPLY POWER TEAM LABEL #420674 TO CONTAINER.
3. INCLUDE PLASTIC BAG CONTAINING THE FOLLOWING:  
 -10000289 OPERATING INSTRUCTIONS.  
 -105363 PRODUCT REGISTRATION FORM.

PRODUCT: WRENCH, LINK ASSEMBLY		
TORQUE OUTPUT:	3,973 lb*ft	(5,386 nm)
PRESSURE:	10,000 psi	(700 bar)
LOW CLEARANCE HEAD RANGE:	1.57in-3.15in	40mm-80mm
LOW CLEARANCE LINK SIZE:	---	---
SQUARE DRIVE SIZE:	---	---
WEIGHT:	4.40 lb	(2.0 kg)

REFERENCE DRAWING NUMBER "TWLC4DIM" FOR DIMENSIONS.

ITEM NO.	QTY	SPX P/N	DESCRIPTION	PART NUMBER
1	1	TWLC4-P01	BODY, TWLC4	LDFBD040001
2	1	TWLC4-P02	PLATE, TWLC4 TOP	LDFTP040001
3	1	TWLC4-P03	PISTON, TWLC4	DFTPI040001
4	1	TWLC4-P04	ROD, TWLC4 PISTON	DFTRD040001
5	1	TWLC4-P05	GLAND, TWLC4	DFTGL040001
6	1	TWLC4-P06	SHUTTLE, TWLC4	DFTSH040001
7	1	TWLC4-P07	PIN, TWLC4 SHUTTLE	DFTSP040001
8	1	TWLC2-P07	POST, TWLC2 MULTI-SWIVEL	DFTSP010001
9	1	TWLC2-P08	BANJO, TWLC2 MULTI-SWIVEL	DFTSB010001
10	1	TWLC2-P09	YOKE, TWLC2 MULTI-SWIVEL ADVANCE	DFTAY010001
11	1	TWLC2-P10	YOKE, TWLC2 MULTI-SWIVEL RETRACT	DFTAS010003
12	1	TWLC4-P12	SEAL KIT, TWLC4 BODY	DFTAS040005
13	1	TWLC2-P12	SEAL KIT, TWLC2 MULTI-SWIVEL	DFTAS010004
14	2	TWLC4-P14	SPRING, TWLC4	STDST000018
15	1	TWLC2-P14	SPRING, TWLC2	STDST000021
16	2	TWLC4-P16	SCREW, TWLC4	STDFA000058
17	1	TWLC4-P17	SCREW, TWLC4	STDFA000033
18	3	TWLC2-P17	PLUG, TWLC2	STDFA000069
19	4	TWLC2-P18	SCREW, TWLC2	STDFA000025
20	1	TWLC2-P19	SCREW, TWLC2	STDFA000027
21	1	TWLC2-P20	CLIP, TWLC2	STDRC000041
22	1	TWLC2-P21	SPRING, TWLC2 PLUNGER	STDST000040
23	1	TWLC2-P22	ADAPTOR, TWLC2	INTHC000002
24	1	TWLC2-P23	COUPLING, TWLC2 MALE	STDHC000004
25	1	TWLC2-P24	COUPLING, TWLC2 FEMALE	STDHC000005
26	2	TWLC4-P26	SCREW, TWLC4	STDFA000026
27	2	TWLC4-P27	SCREW, TWLC4	STDFA000029
28	1	1000291	DECAL, TWLC4 CE	LDFLA040002
29	1	1000323	DECAL, TW COUNTRY OF ORIGIN	SPXLA000004
30	1	1000079	DECAL, TORQUE WRENCH WARNING	SPXLA000001
31	1	1000082	DECAL, TORQUE WRENCH WARNING	SPXLA000002
32	1	251057	DECAL, WARNING	SPXLA000005

DECAL 420674 APPLIED TO CORNER OF BOX AS SHOWN

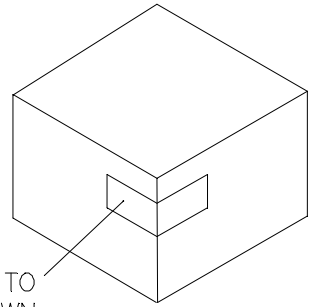

THIRD ANGLE PROJECTION THE INFORMATION CONTAINED IN THIS DRAWING IS THE SOLE PROPERTY OF SPX FLUID POWER. ANY REPRODUCTION IN PART OR AS A WHOLE WITHOUT WRITTEN PERMISSION OF SPX FLUID POWER IS STRICTLY PROHIBITED.	TOLERANCES UNLESS NOTED ANGLES ± 1° 1 PLACES ± .020 2 PLACES ± .010 3 PLACES ± .005 4 PLACES ± .001 FINISH 125 MAX C/B .020	DRAWN N.AUSTIN BY	DATE DRAWN 8/13/07	FOR PART or OPER.	Rockford, IL.	TRACKING NUMBER NP0710
	CHECKED B.PETERSON BY	DATE CHECKED 05/28/2008	HEAT TREAT	DRAWING NAME WRENCH, TORQUE	SCALE 1:1 SIZE D	REV 0
	MATERIAL NOTED	ALT. MATERIAL	FINISH	DRAWING NUMBER TWLC4	SHEET 1 of 1	