

FOR INTERNAL USE ONLY

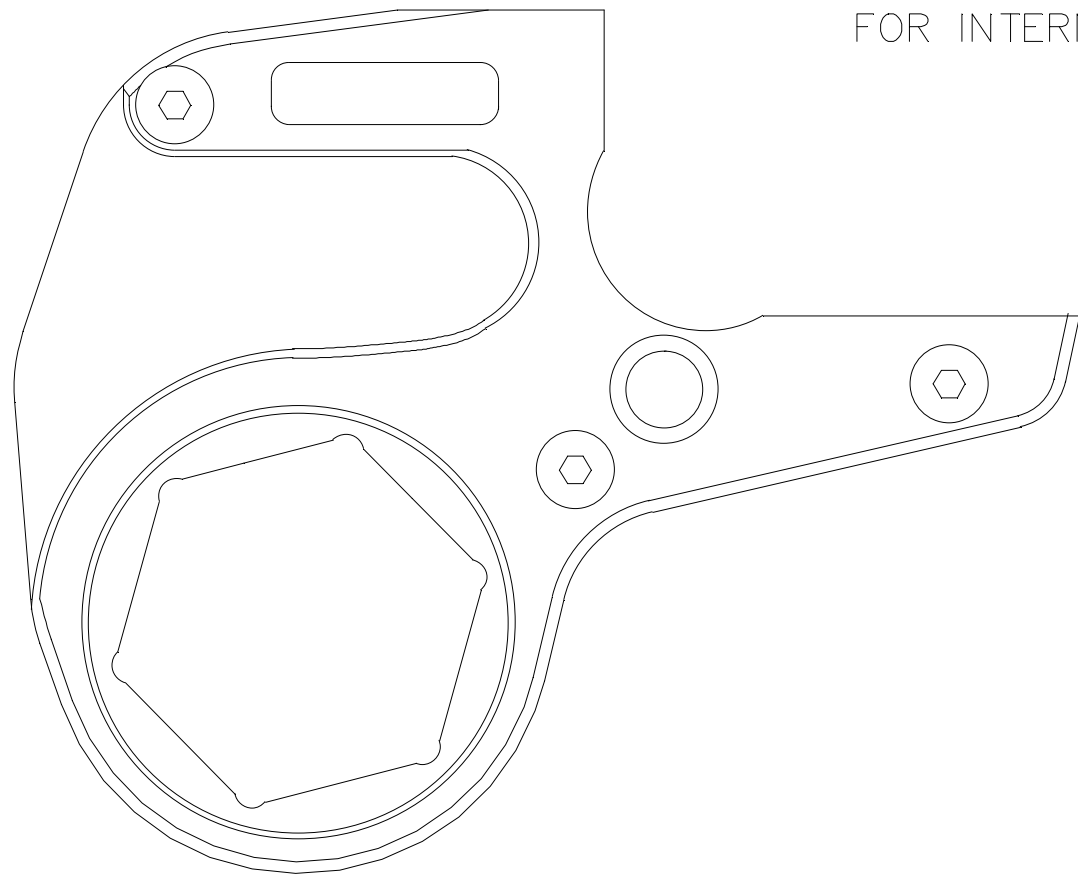

ITEM NO.	QTY	SPX P/N	DESCRIPTION	PART NUMBER
1	1	TWL4-041-P01	SLIDER, TWL4-041	DFTSL040001
2	1	TWL2-032-P02	PIN, TWL2-032 CRANK	MODFA000028
3	1	TWL4-041-P03	SPRING, TWL4-041 LEAF	DFTLS040001
4	2	TWL2-032-P04	SCREW, TWL2-032	STDFA000088
5	2	TWL4-041-P05	SPRING, TWL4-041	STDST000013
6	2	TWL4-041-P06	SCREW, TWL4-041	STDFA000045
7	1	TWL4-041-P07	SCREW, TWL4-041	STDFA000043
8	1	TWL4-060-P08	PLATE, TWL4-060 LEFT SIDE	DFTPL040005
9	1	TWL4-060-P09	PLATE, TWL4-060 RIGHT SIDE	DFTPR040005
10	1	TWL4-060-P10	CRANK, TWL4-060	DFTCR040005
11	1	TWL4-060-P11	SHOE, TWL4-060 DRIVER	DFTDS040005
12	1	TWL4-060-P12	RATCHET, TWL4-060 2-3/8"/60mm A/F	DFTRT04005D
13	2	TWL4-060-P13	BUSHING, TWL4-060 SIDE PLATE	DFTSB040005
14	1	TWL2-032-P13	SCREW, TWL2-032	STDFA000062
15	1	TWL4-041-P15	PIN, TWL4-041 HEAD	DFTHP040001
16	1	1000296	DECAL, TWL4 PT BRAND	DFTLA040002
17	1	1000301	DECAL, TWL4 PD BRAND	DFTLA040003
18	1	1000323	DECAL, TW COUNTRY OF ORIGIN	SPXLA000004

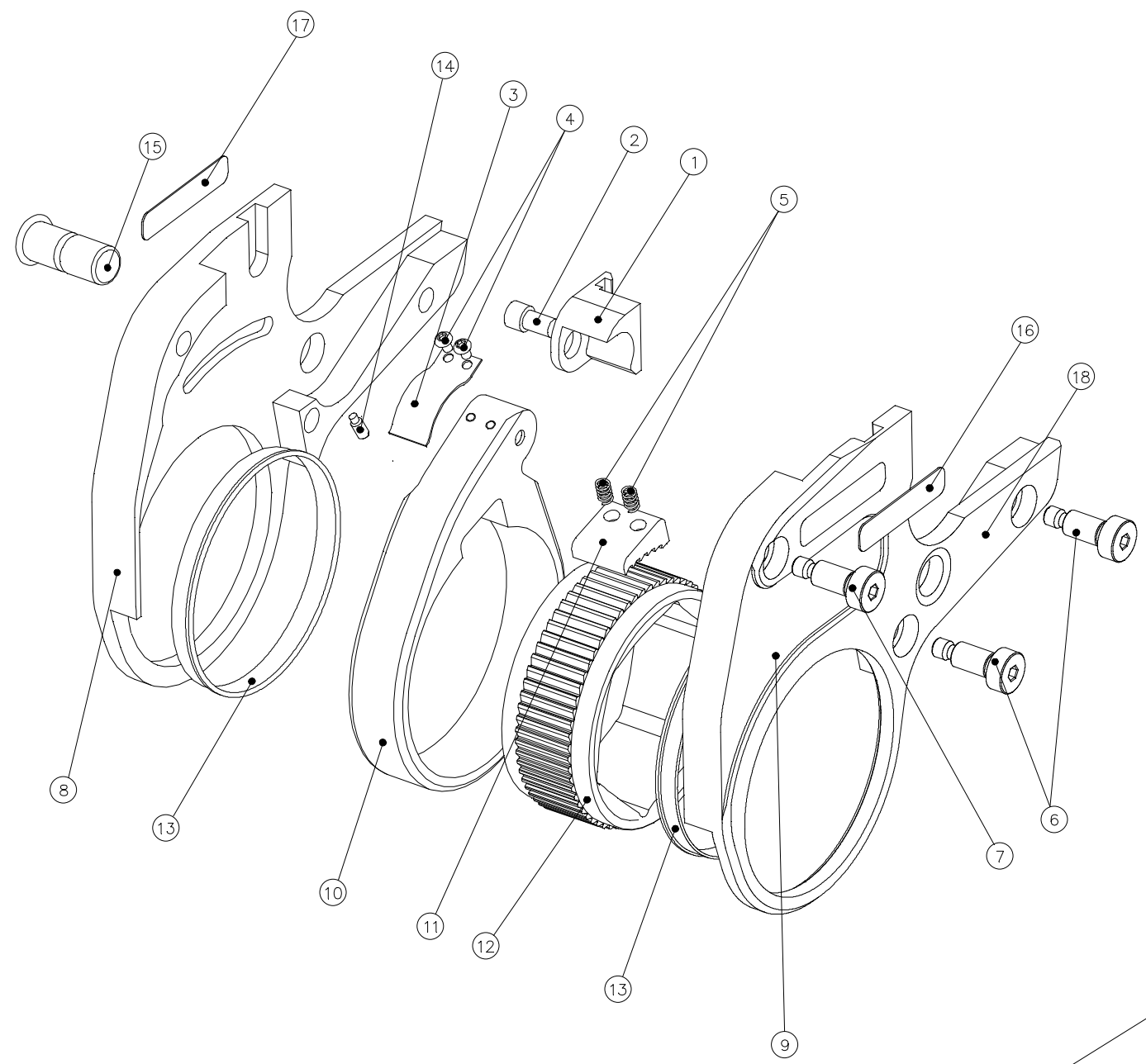
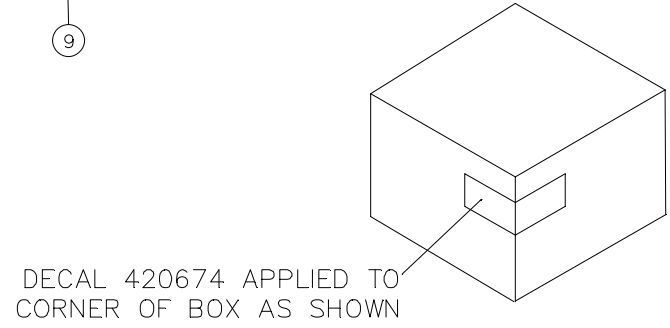

1. ALL WRENCHES TO BE DATE CODED PER SUPPLIER'S STANDARD PROCEDURE.
2. APPLY POWER TEAM LABEL #420674 TO CONTAINER.
3. INCLUDE PLASTIC BAG CONTAINING THE FOLLOWING:  
-10000289 OPERATING INSTRUCTIONS.  
-105363 PRODUCT REGISTRATION FORM.

PRODUCT: WRENCH, LINK ASSEMBLY		
TORQUE OUTPUT:	---	---
PRESSURE:	10,000 psi	(700 bar)
LOW CLEARANCE HEAD RANGE:	---	---
LOW CLEARANCE LINK SIZE:	2.36 in	(60 mm)
SQUARE DRIVE SIZE:	---	---
WEIGHT:	8.14 lb	(3.7 kg)

REFERENCE DRAWING NUMBER "TWL4-XXXDIM" FOR DIMENSIONS.

THIRD ANGLE PROJECTION  
  
 THE INFORMATION CONTAINED IN THIS DRAWING IS THE SOLE PROPERTY OF SPX FLUID POWER. ANY REPRODUCTION IN PART OR AS A WHOLE WITHOUT WRITTEN PERMISSION OF SPX FLUID POWER IS STRICTLY PROHIBITED.

TOLERANCES UNLESS NOTED  
 ANGLES ± 1°  
 1 PLACES ± .020  
 2 PLACES ± .010  
 3 PLACES ± .005  
 4 PLACES ± .001  
 FINISH 125 MAX C/B .020

DRAWN BY N.AUSTIN  
 CHECKED BY B.PETERSON  
 MATERIAL NOTED

DATE DRAWN 8/13/07  
 DATE CHECKED 05/28/2008  
 ALT. MATERIAL

FOR PART or OPER.  
 HEAT TREAT  
 FINISH

**SPX**  
 HYDRAULIC TECHNOLOGIES

DRAWING NAME WRENCH HEAD, TORQUE 2.38 (60MM)  
 DRAWING NUMBER TWL4-060

TRACKING NUMBER NP0710  
 SCALE 1:1  
 SIZE D  
 REV 0  
 SHEET 1 of 1