

# ZU4 Electric Torque Wrench Pumps

▼ ZU4204TB-EHK (shown with optional heat exchanger and skidbar), ZU4204BB-QH



- Features Z-CLASS high-efficiency pump design; higher oil flow and bypass pressure, cooler running and requires 18% less current draw than comparable pumps
- Powerful 1.7 hp universal electric motor provides high power-to-weight ratio and excellent low-voltage operating characteristics
- High-strength, molded composite shroud protects motor and electrical components, while providing an ergonomic, non-conductive handle for easy transport
- Low-voltage pendant provides additional safety for the operator

## Pro Series pump only

- LCD readout provides pressure display and a number of diagnostic and readout capabilities never before offered on a portable electric pump
- AutoCycle feature provides continuous cycle operation of the torque wrench as long as the advance button is pressed (pump can be used with or without auto cycle feature)



◀ Any brand of hydraulic torque wrench can be powered by the portable ZU4-Series torque wrench pump.

**Z** Tough.  
Dependable.  
Innovative.  
**Z-CLASS**



### Classic Electrical

Basic electrical package includes mechanical contactor, ON/OFF toggle switch, pendant with electro-mechanical pushbuttons, 24V transformer timer and operator accessible circuit breaker.



### Pro Series

Back-lit LCD and pressure transducer featuring AutoCycle technology.

- Digital read-out and “AutoCycle” setting
- Pump usage information, hour and cycle counts
- Low-voltage warning and recording
- Self-test and diagnostic capabilities
- Information can be displayed in English, French, German, Italian, Spanish and Portuguese
- Pressure transducer is more accurate and durable than analog gauges
- Easy-viewing variable rate display
- Display pressure in bar, MPa or psi

# ZU4 Torque Wrench Pumps



## Z-CLASS – A Pump For Every Application

Patented Z-CLASS pump technology provides high by-pass pressures for increased productivity—important in applications using long hose runs and high pressure-drop circuits, like heavy lifting or certain double-acting tools.

Enerpac ZU4 Hydraulic Pumps are built to power small to large torque wrenches. Choosing the right ZU4 torque wrench pump for your application is easy.

### Classic Electric Torque Wrench Pump

- The Classic has traditional electro-mechanical components (transformers, relays and switches) in place of solid-state electronics. The Classic delivers durable, safe and efficient hydraulic power.

### Pro Series Electric Torque Wrench Pump

- Digital (LCD) display features a built-in hour meter, pressure display and shows self-diagnostic, cycle-count and low voltage warning information. These premium features are not available on any other pump—anywhere!
- AutoCycle feature provides continuous cycle operation of the torque wrench as long as the advance button is pressed. (Pump can be used with or without AutoCycle feature).

## ZU4 Series



Reservoir Capacity:

**1 and 1.75 gal.**

Flow at 10,000 psi:

**60 in<sup>3</sup>/min.**

Motor Size:

**1.7 hp**

Maximum Operating Pressure:

**10,000 psi**

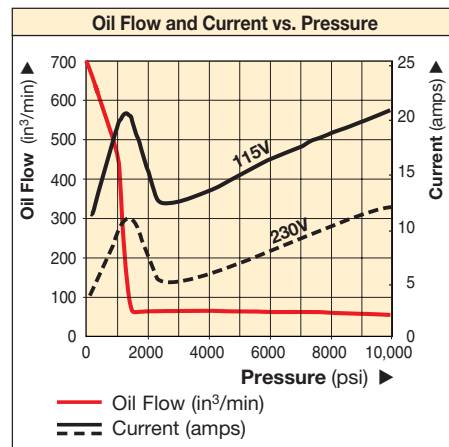

### ▼ COMMON PUMP MODELS

	For Use With Torque Wrenches	Model Number <sup>1)</sup>	Motor Electrical Specification	Usable Oil Capacity (gal)	Weight with Oil (lbs)
Pro Series	All wrenches	ZU4204TB-Q	115 VAC, 1-ph	1.0	70
		ZU4208TB-Q	115 VAC, 1-ph	1.75	76
		ZU4204TE-Q <sup>2)</sup>	208-240 VAC, 1-ph	1.0	70
		ZU4208TE-Q <sup>2)</sup>	208-240 VAC, 1-ph	1.75	76
		ZU4204TI-Q <sup>3)</sup>	208-240 VAC, 1-ph	1.0	70
		ZU4208TI-Q <sup>3)</sup>	208-240 VAC, 1-ph	1.75	76
Classic	All wrenches	ZU4204BB-QH	115 VAC, 1-ph	1.0	82
		ZU4204BB-Q	115 VAC, 1-ph	1.0	73
		ZU4208BE-QH <sup>2)</sup>	208-240 VAC, 1-ph	1.75	83
		ZU4204BE-Q <sup>2)</sup>	208-240 VAC, 1-ph	1.0	74
		ZU4208BI-QH	208-240 VAC, 1-ph	1.75	88
		ZU4208BI-Q	208-240 VAC, 1-ph	1.75	79

<sup>1)</sup> All models meet CE safety requirements and all CSA requirements.

<sup>2)</sup> European plug and CE EMC directive compliant

<sup>3)</sup> With NEMA 6-15 plug



### Torque Wrench Pump Selection Matrix

For optimum speed and performance see the torque wrench pump and hose selection matrix.

Page: **28**



### Accessory Options

Available by placing the following additional suffix at the model number end:

- H** = Heat Exchanger
- K** = Skidbar
- M** = 4-wrench manifold
- R** = Roll cage



### Gauge Overlay Kit

Gauge overlay kits are also available separately. **GT-4015** includes overlays for all SQD and HXD torque wrenches. **GT-4015-Q** includes overlays for all S- and W-Series torque wrenches.

# ZU4 Ordering Matrix and Specifications

▼ This is how a ZU4 Series pump model number is built up:



1	2	3	4	5	6	7	8	8	8
Product Type	Motor Type	Flow Group	Valve Type	Reservoir Size	Valve Operation	Voltage	Must be E or Q	Options	Options

### 1 Product Type

**Z** = Pump series

### 2 Motor Type

**U** = Universal electric motor

### 3 Flow Group

**4** = 60 in<sup>3</sup>/min @ 10,000 psi

### 4 Valve Type

**2** = Torque wrench valve

### 5 Reservoir Size (useable capacity)

**04** = 1.0 gallon

**08** = 1.75 gallons

### 6 Valve Operation

**T** = Solenoid valve with pendant, LCD Electric and pressure transducer.

**B** = Solenoid valve with pendant, classic electrical

### 7 Voltage

**B** = 115V, 1 ph, 50/60 Hz

**E** = 208-240V, 1 ph, 50/60 Hz (with European plug CE RF compliant)

**I** = 208-240V, 1 ph, 50/60 Hz (with NEMA 6-15 plug)

### 8 Factory installed features and options

**E** = 11,600 coupler for use with HXD-, SQD-Series or other wrenches

**Q** = 10,000 coupler for use with S- and W-Series or other wrenches

**H** = Heat exchanger

**K** = Skidbar

**M** = 4-wrench manifold

**R** = Roll cage



How to order your ZU4-Series torque wrench pump

### Ordering Example 1

#### Model No. ZU4208TB-QMHK

10,000 psi pump for use with Enerpac S- and W-Series and other 10,000 psi torque wrenches, 115V motor, 1.75 gallon reservoir, 4-wrench manifold, heat exchanger and skidbar.

Refer to the torque wrench pump selection matrix for optimum wrench, pump and hose combinations.

Page: 28



### Twin Torque Wrench Hoses

Use Enerpac THQ-700 series twin hoses with 10,000 psi pumps.

10,000 psi	
19.5 feet long, 2 hoses	<b>THQ-706T</b>
39 feet long, 2 hoses	<b>THQ-712T</b>

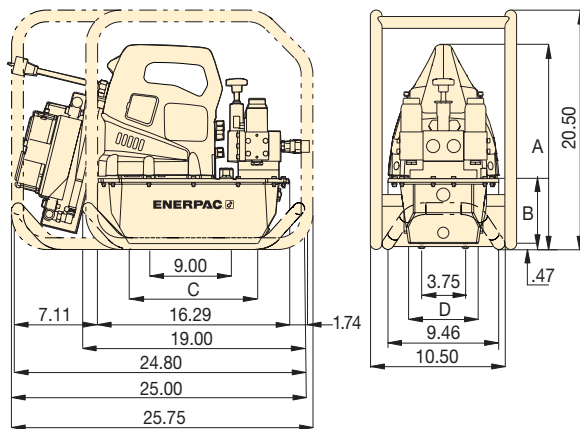

### ZU4-Series Torque Wrench Pumps

Reservoir Size (useable gallons)	A (in)	B (in)	C (in)	D (in)
<b>1</b>	17.0	5.6	11.0	6.0
<b>1.75</b>	17.0	5.6	8.1	6.6

Dimensions shown in inches

- ① User adjustable relief valve
- ② Heat Exchanger (optional)
- ③ Skidbar (optional)
- ④ 4-wrench manifold (optional)
- ⑤ Roll cage (optional)

ZU4 Performance							
Motor Size (hp)	Output Flow Rate (in <sup>3</sup> /min)				*Motor Electrical Specification	Sound Level (dBA)	Relief Valve Adjustment Range (psi)
	100 psi	700 psi	5,000 psi	10,000 psi			
1.7	700	535	76	60	115 VAC, 1-ph 208-240 VAC, 1-ph	85-90	1,800-10,000**

\* 50/60 hz

\*\* Pump type (-Q) shown.

▼ Most hydraulic torque wrenches can be powered by the Enerpac ZU4-Series torque wrench pump.



# ZU4 Torque Wrench Pump Options



## Heat Exchanger

- Removes heat from the bypass oil to provide cooler operation
- Stabilizes oil viscosity, increasing oil life and reduces wear of pump and other hydraulic components

Accessory Kit No. *	Can be used on ZU4-Series torque wrench pumps
ZHE-U4	1 and 1.75 gallon reservoir

\* Add suffix **H** to pump model number for factory installation.  
Heat Exchanger adds 9.1 lbs. to pump weight.

Ordering Example :  
Model No. ZU4208TE-H

Thermal Transfer *	Max. Pressure	Max. Oil Flow	Voltage
Btu/h	(psi)	(gpm)	(VDC)
900	300	7.0	12

\* At 5 gpm at 70 °F ambient temperature.

Do not exceed maximum oil flow and pressure ratings. Heat exchanger is not suitable for water-glycol or high water-based fluids.



## Skidbar

- Provides greater pump stability on soft or uneven surfaces
- Provides easy two-handed lift

Accessory Kit No. *	Can be used on ZU4-Series torque wrench pumps
SBZ-4	1 and 1.75 gallon <sup>1)</sup>
SBZ-4L	1 and 1.75 gallon <sup>2)</sup>

\* Add suffix **K** to pump model number for factory installation.

<sup>1)</sup> Without heat exchanger 4.9 lbs.

<sup>2)</sup> With heat exchanger 7.0 lbs.

Ordering Example :  
Model No. ZU4208TB-QK



## Roll Bar Cage

- Protects pump
- Provides greater pump stability

Accessory Kit No. *	Can be used on ZA4-Series torque wrench pumps
ZRC-04	1 and 1.75 gallon reservoir <sup>1)</sup>
ZRC-04H	1 and 1.75 gallon reservoir <sup>2)</sup>

\* Add suffix **R** for factory installation.

<sup>1)</sup> Without heat exchanger

<sup>2)</sup> With heat exchanger

Ordering Example :  
Model No. ZU4208BB-QR

## ZU4 Series



Reservoir Capacity:

**1 and 1.75 gal.**

Flow at 10,000 psi:

**60 in<sup>3</sup>/min.**

Motor Size:

**1.7 hp**

Maximum Operating Pressure:

**10,000 psi**



## 4-Wrench Manifold

- For simultaneous operation of multiple torque wrenches
- Can be factory installed or ordered separately

Accessory Kit No. *	Can be used on ZU4-Series torque wrench pumps
ZTM-U4Q	for 10,000 psi torque wrenches

\* Add suffix **M** to pump model number for factory installation.

Ordering Example :  
Model No. ZU4208TB-QM