

▼ Shown from left to right: ZE3304MB-K, ZE4110DB-FHR







The New Standard for Industrial Applications, Z-Class



Oil Level Indicators

All ZE pumps feature an oil level indicator—sight glasses on the 1 and 2 gallon reservoirs and oil level gauges on the 2.5, 5 and 10 gallon reservoirs.

▼ SELECTION CHART *

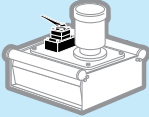
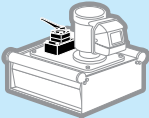
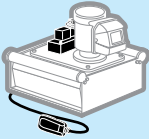
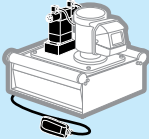
BASIC PUMP CONFIGURATIONS Select your ZE pump model here for most applications. For special requirements, see the ZE Pump ordering matrix.		Pump Type	Used with Cylinder		Valve Function			Valve** Model Number	Useable Oil Capacity (gal)
									
MANUAL VALVE CONTROL	Manual Valve without electric box or LCD <ul style="list-style-type: none"> Ideal choice for most applications Manual valve control, for both single-acting or double-acting applications Manual motor control On/off switch on 1-phase electric motor 		●		●		●	VM32	2.0
			●		●	●	●	VM33	2.0
			●		●	●	●	VM33	5.0
			●		●	●	●	VM33	10.0
				●	●	●	●	VM43	2.0
				●	●	●	●	VM43	5.0
				●	●	●	●	VM43	10.0
MANUAL VALVE CONTROL	Manual Valve with electric box and LCD <ul style="list-style-type: none"> Ideal choice for most applications Manual valve control, for both single-acting or double-acting applications Manual motor control 		●		●		●	VM32	2.0
			●		●		●	VM32	2.5
			●		●	●	●	VM33	5.0
			●		●	●	●	VM33	10.0
				●	●	●	●	VM43	5.0
				●	●	●	●	VM43	10.0
				●	●	●	●	VM43	10.0
REMOTE VALVE CONTROL	Solenoid Dump Valve with electric box and LCD <ul style="list-style-type: none"> Ideal for punching, crimping and cutting For use when load holding is not required Push-button control pendant with 10 ft. cord controls the valve and motor 		●		●		●	VE32D	1.0
			●		●		●	VE32D	2.0
			●		●		●	VE32D	2.5
			●		●		●	VE32D	5.0
	Solenoid 3-position Valve with Electric Box and LCD <ul style="list-style-type: none"> Ideal for production and lifting applications All valves are 3-position for Advance-Hold-Retract Push-button control pendant with 10 ft. cord controls the valve and motor 		●		●	●	●	VE33	2.0
			●		●	●	●	VE33	2.5
			●		●	●	●	VE33	5.0
				●	●	●	●	VE43	2.0
				●	●	●	●	VE43	2.5
				●	●	●	●	VE43	5.0
	●	●	●	●	VE43	10.0			

* Models in this chart are 115 VAC, 1-phase at 50/60 Hz for ZE3-4 or 220 VAC, 3 phase at 50/60 Hz for ZE5-6. For other options, please refer to the ZE Pump ordering matrix. ** See Valve Section for technical information.

ZE-Series Electric Pumps

- Features **Z-Class** high-efficiency pump design; higher oil flow and by-pass pressure, cooler running and requires 18% less current draw than comparable pumps
- Totally enclosed, fan-cooled industrial electric motors supply extended life and stand up to harsh industrial environments
- Low-voltage pendant, on certain models, provides additional safety for the operator
- Multiple valve and reservoir configurations provide application specific models to match the most demanding industrial applications
- High-strength, molded electrical enclosure protects electronics, power supplies and LCD readout from harsh industrial environments
- LCD readout provides a number of diagnostic and readout capabilities never before offered on an industrial pump (included with electric valve models, optional on other models)

ZE Series



Reservoir Capacity:

1.0-10.0 gal.

Flow at Rated Pressure:

40-200 in³/min

Motor Size:

1.0-7.5 hp

Maximum Operating Pressure:

10,000 psi



User Adjustable Relief Valve

All VM and VE-Series have a user adjustable relief valve to allow the operator to easily set the optimum working pressure.



Locking Valves

For applications requiring positive load holding, VM-Series valves (except VM32) are available with a pilot-operated check valve. This provides hydraulic locking of the load until the valve is shifted into the retract position. To order this feature on your ZE-series pump see the valve type in the order matrix.

Page: 110



Single-Stage or Two-Stage

Choose single-stage pumps for applications that require constant flow regardless of pressure, such as testing or clamping. Two-stage pumps have an increased output flow at low pressure to allow fast movement towards the load, for reduced cycle times and increased productivity. To specify a single-stage pump, place the letter "S" at the end of the model number. For example: **ZE5320LG-S**

ZE3 Series (1.0 hp) Output Flow Rate at 10,000 psi: 40 in ³ /min		ZE4 Series (1.5 hp) Output Flow Rate at 10,000 psi: 60 in ³ /min		ZE5 Series (3.0 hp) Output Flow Rate at 10,000 psi: 120 in ³ /min		ZE6 Series (7.5 hp) Output Flow Rate at 10,000 psi: 200 in ³ /min	
Model Number	Weight (lbs)	Model Number	Weight (lbs)	Model Number	Weight (lbs)	Model Number	Weight (lbs)
ZE3208MB	91	ZE4208MB	100	-	-	-	-
ZE3308MB	92	ZE4308MB	101	-	-	-	-
ZE3320MB	132	ZE4320MB	141	ZE5320MG	152	ZE6320MG	191
ZE3340MB	183	ZE4340MB	192	ZE5340MG	203	ZE6340MG	242
ZE3408MB	92	ZE4408MB	101	-	-	-	-
ZE3420MB	132	ZE4420MB	141	ZE5420MG	152	ZE6420MG	191
ZE3440MB	183	ZE4440MB	192	ZE5440MG	203	ZE6440MG	242
ZE3208LB	96	ZE4208LB	105	-	-	-	-
ZE3210LB	109	ZE4210LB	112	ZE5210LG	132	ZE6210LG	171
ZE3320LB	138	ZE4320LB	146	ZE5320LG	160	ZE6320LG	199
ZE3340LB	188	ZE4340LB	197	ZE5340LG	210	ZE6340LG	249
ZE3420LB	138	ZE4420LB	145	ZE5420LG	160	ZE6420LG	199
ZE3440LB	189	ZE4440LB	197	ZE5440LG	210	ZE6440LG	250
ZE3104DB	94	ZE4104DB	103	-	-	-	-
ZE3108DB	105	ZE4108DB	109	-	-	-	-
ZE3110DB	114	ZE4110DB	122	ZE5110DG	136	ZE6110DG	175
ZE3120DB	141	ZE4120DB	149	ZE5120DG	163	ZE6120DG	202
ZE3140DB	190	-	-	-	-	-	-
ZE3308SB	112	ZE4308SB	121	-	-	-	-
ZE3310SB	125	ZE4310SB	134	ZE5310SG	147	ZE6310SG	187
ZE3320SB	152	ZE4320SB	161	ZE5320SG	174	ZE6320SG	213
ZE3408SB	112	ZE4408SB	121	-	-	-	-
ZE3410SB	125	ZE4410SB	134	ZE5410SG	147	ZE6410SG	187
ZE3420SB	152	ZE4420SB	161	ZE5420SG	174	ZE6420SG	213
ZE3440SB	203	ZE4440SB	212	ZE5440SG	225	ZE6440SG	264

* All models in this chart are 115 VAC, 1-phase at 50/60 Hz. For other options please refer to the ZE Pump ordering matrix.

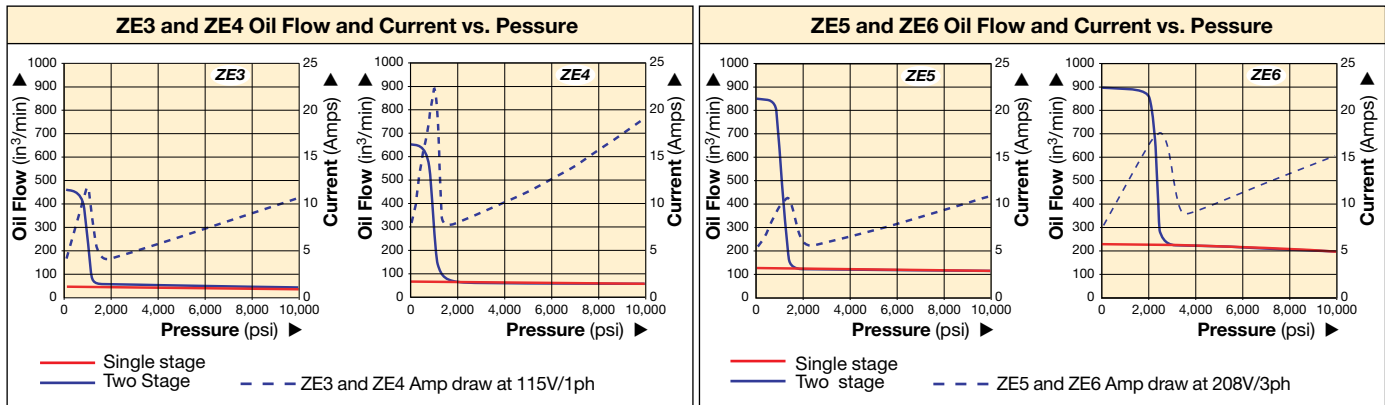

ZE-Series Pumps with 1 and 2 gallon reservoir

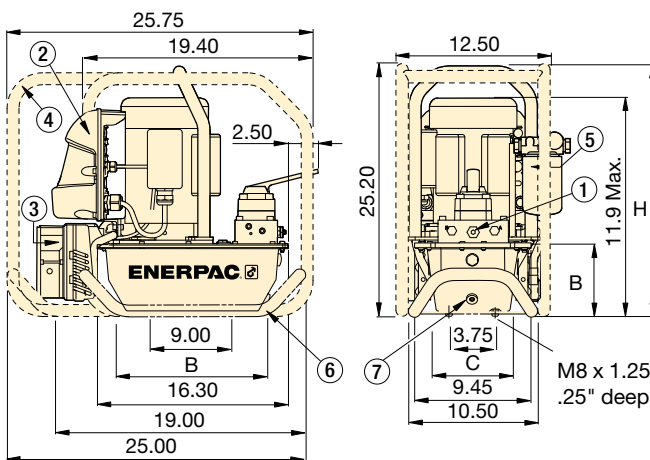

ZE-Series Pumps with 2.5, 5, 10 gallon reservoir

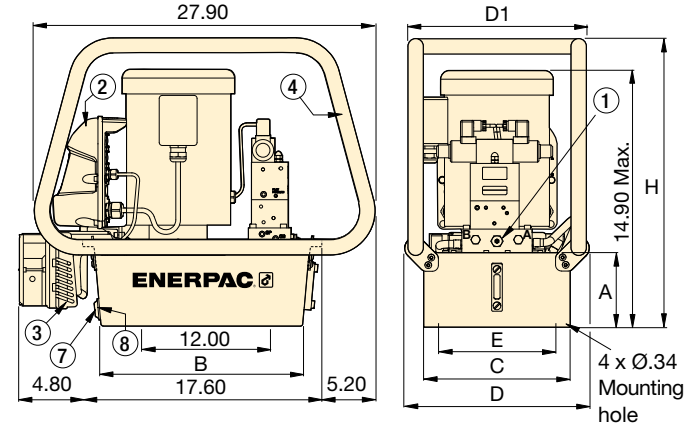

Reservoir Size (useable oil) (gal)	ZE-Series Pump Dimensions (in)						
	A	B	C	D	D1	E	H
1.0	5.6	11.0	6.0	-	-	-	20.2
2.0	5.6	11.0	8.1	-	-	-	22.6
2.5	6.2	16.5	12.0	15.1	14.6	11.0	23.6
5.0	7.1	16.5	16.6	19.7	19.2	15.6	24.6
10.0	10.6	15.7	19.9	22.7	22.5	18.9	28.1

- ① User adjustable relief valve on all manual and solenoid valves:
3/8" NPTF on A and B ports
1/4" NPTF on auxiliary ports
- ② Electric Box (Optional w/manual valve)
- ③ Heat Exchanger (Optional)
- ④ Roll Bar (Optional)
- ⑤ Return Line Filter (Optional)
- ⑥ Skid Bar (Optional)
- ⑦ Oil Drain
- ⑧ Oil Level/Temperature Switch (Optional)

▼ PERFORMANCE CHART

Pump Series	Operation	Output Flow Rate (in³/min)				Available Reservoir Sizes (useable oil) (gal)	Motor Size		Relief Valve Adjustment Range (psi)	Sound Level (dBA)
		100 psi	700 psi	5,000 psi	10,000 psi		hp	RPM		
ZE3	Single-stage	43	43	42	40	1, 2, 2.5, 5, 10	1.0	1750	1000 - 10,000	75
	Two-stage	450	385	42	40					
ZE4	Single-stage	64	64	62	60	1, 2, 2.5, 5, 10	1.5	1750	1000 - 10,000	75
	Two-stage	650	600	62	60					
ZE5	Single-stage	128	126	123	120	2.5, 5, 10	3.0	1750	1000 - 10,000	75
	Two-stage	850	825	123	120					
ZE6	Single-stage	220	215	210	200	2.5, 5, 10	7.5	3450	1000 - 10,000	80
	Two-stage	900	890	210	200					

Output flow rate is listed at 60 Hz.
Flow rate will be approximately 5/6 of these values at 50 Hz.

ZE Electric Pump Ordering Matrix

CUSTOM BUILD YOUR ZE SERIES PUMP

If the ZE Series pump that would best fit your application cannot be found in the chart on page 88, you can easily build your custom ZE Series pump here.

▼ This is how a ZE Series Pump model is built up:

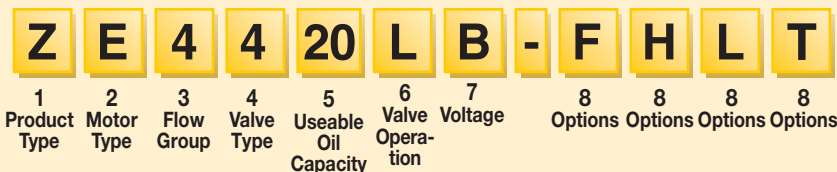

1 Product Type

Z = Pump Class

2 Prime movers

E = Induction Electric Motor

3 Flow Group

- 3** = 40 in³/min @ 10,000 psi
- 4** = 60 in³/min @ 10,000 psi
- 5** = 120 in³/min @ 10,000 psi¹⁾
- 6** = 200 in³/min @ 10,000 psi¹⁾

4 Valve Types

- 0** = No valve w/coverplate
- 1** = Dump (VE32D)
- 2** = 3 way/2 position manual or electric (VM32 or VE32)
- 3** = 3 way/3 position manual or electric (VM33 or VE33)
- 4** = 4 way/3 position manual or electric (VM43 or VE43)
- 6** = 3 way/3 position locking manual w/po check (VM33L)
- 7** = 3 way/2 position manual (VM22)
- 8** = 4 way/3 position locking manual w/po check (VM43L)

5 Useable Oil Capacity

- 04** = 1.0 gallon²⁾
- 08** = 1.75 gallon²⁾
- 10** = 2.5 gallon
- 20** = 5.0 gallon
- 40** = 10.0 gallon

6 Valve Operation

- D** = Dump valve (w/ pendant and LCD)
- L** = Manual valve (w/o pendant, w/ LCD)
- M** = Manual valve⁶⁾ (w/o pendant or LCD)
- N** = No valve⁶⁾ (no electrical box)
- S** = Solenoid valve (w/ pendant and LCD)
- W** = No valve (w/o pendant and LCD)

7 Voltages

- Single Phase
 - B** = 115V 1 ph 50-60Hz³⁾
 - E** = 208-240V 1 ph 50-60 Hz European Plug
 - I** = 208-240V 1 ph 50-60 Hz USA Plug
- Three Phase⁶⁾
 - M** = 190-200V 3ph 50-60Hz
 - G** = 208-240V 3ph 50-60Hz
 - W** = 380-415V 3ph 50-60Hz
 - K** = 440V 3ph 50-60Hz
 - J** = 460-480V 3ph 50-60Hz
 - R** = 575V 3ph 60Hz

8 Options (specify in alphabetical order)

- | | |
|--|---|
| F = Filter | P = Pressure switch ⁴⁾ |
| G = 0-15,000 psi gauge (2 ¹ / ₂ " ⁷⁾ | R = Roll bar |
| H = Heat exchanger ⁴⁾ | S = Single stage |
| K = Skidbar (1 and 2 gal. reservoirs only) | T = Pressure transducer ^{4) 7)} |
| L = Level/temp switch ^{4) 5)} | U = Foot switch ⁴⁾ |
| N = No reservoir handles (includes lifting eyes) | |

- 1) ZE5 and ZE6 series pumps only available with 3-phase motors.
- 2) 1 and 2 gallon reservoirs only available on ZE3 and ZE4 series pumps.
- 3) 115 volt pumps are supplied with 15 amp plug for intermittent use. 20 amp circuit recommended for frequent full pressure use.
- 4) These options require LCD electrical package. Pressure switch option only available on manual valves without locking valve. The LCD electrical package can accept either a pressure switch or pressure transducer, but not both.
- 5) Not available with 1 and 2 gallon reservoirs.
- 6) Standard Electric models with 3-phase motors are shipped without cord, motor starter or overload protection.
- 7) Pressure gauge not available on pump models with pressure transducer. Pressure transducer provides digital pressure readout on LCD display.

ZE Series



Reservoir Capacity:

1.0-10.0 gal.

Flow at Rated Pressure:

40-200 in³/min.

Motor Size:

1.0-7.5 hp

Maximum Operating Pressure:

10,000 psi



Ordering Example 1

Model Number: ZE4420MB

ZE4420MB is a 60 in³/min, 10,000 psi pump with a 4 way, 3-position manual valve, a 5 gallon reservoir, operates on a 115 VAC 1 ph 50/60 Hz motor and includes standard electrical package.

Ordering Example 2

Model Number: ZE6440SG-HNU

ZE6440SG-HNU is a 200 in³/min, 10,000 psi pump with a 4 way, 3-position electric valve, a 10 gallon reservoir, operates on a 230 VAC 3 ph 50/60 Hz motor. It includes LCD electrical package and foot switch on 10 ft cord, no reservoir handles and the optional heat exchanger.



Single-Stage or Two-Stage

Choose single-stage pumps for applications that require constant flow regardless of pressure, such as testing or clamping.

Two-stage pumps have an increased output flow at low pressure to allow fast movement towards the load, for reduced cycle times and increased productivity.



Electric Box ¹⁾

- Back-lit LCD
- Pump usage information, hour and cycle counts
- Low-voltage warning and recording
- Self-test and diagnostic capabilities
- Pressure read-out ²⁾
- Auto-mode pressure setting ²⁾
- Information can be displayed in six languages ³⁾

¹⁾ Included on pumps with solenoid valves. Can be factory installed on pumps with manual valve
²⁾ When used with optional pressure transducer
³⁾ English, French, German, Italian, Spanish and Portuguese



Level/Temperature Switch ⁴⁾

- Shuts down pump before oil level reaches an unsafe level, avoiding damage due to cavitation
- Shuts down pump when unsafe oil temperature is reached
- Ideal if pump is used in remote area without visual access to oil level

⁴⁾ 24 V, requires Electric Box. Available for 2.5, 5 and 10 gallon reservoirs

Accessory Kit Model Number	Fixed Temperature Signal (°F)	Operating Temperature (°F)	Max. Pressure (psi)
ZLS-U4 *	75	40 - 230	150

* Add suffix **L** for factory installation, see ordering matrix.



Return Line Filter

- 25 micron nominal filter removes contaminants from return oil flow before allowing it back into tank
- Internal by-pass valve prevents damage if filter is dirty
- With maintenance indicator
- Replaceable filter element PF25

Accessory Kit Model Number	Maximum Pressure (psi)	Maximum Oil Flow (GPM)	By-pass Setting (psi)
ZPF *	200	12.0	25

* Add suffix **F** for factory installation, see ordering matrix.



Roll Cage

- For easy portability and hoisting
- Protects pump and electric box
- Available for all reservoir sizes

Accessory Kit Number	Fits on Reservoir
ZRC-04 *	1 and 2 gallon ¹⁾
ZRC-04H *	1 and 2 gallon ²⁾
ZRB-10 *	2.5 gallon
ZRB-20 *	5 gallon
ZRB-40 *	10 gallon

* Add suffix **R** for factory installation, see ordering matrix.
¹⁾ Without heat exchanger ²⁾ With heat exchanger



Skid Bar

- Provides easy two-hand lift
- Provides greater pump stability on soft or uneven surfaces

Accessory Kit Number	For ZE-Series Pumps with Reservoir	Weight (lbs)
SBZ-4 *	1-2 gal. w/o heat exchanger	4.9
SBZ-4L *	1-2 gal. with heat exchanger	5.5

* 1 and 2 gallon reservoirs only. Add suffix **K** for factory installation, see ordering matrix.



Foot Switch ⁵⁾

- Hands-free remote control on solenoid dump and 3-position valves
- With 10 foot cord

⁵⁾ 15 V, requires Electric Box

Accessory Kit Number	Can be used on ZE-Series Pumps with
ZCF-2 *	Solenoid VE-Series valves

* Add suffix **U** for factory installation, see ordering matrix.

ZE-Series, Factory Installed Options & Accessories



Pressure Transducer ¹⁾

- Displays pressure on LCD in bar, MPa or psi
- More accurate than analog gauge
- Calibration can be fine-tuned for certification
- Easy-viewing variable rate display
- “Set pressure” feature turns off motor at user defined pressure (or shifts valve to neutral on models with VE33/ VE43 valves)

¹⁾ 24 V, requires Electric Box

Accessory Kit Model number	Adjustable Pressure Range (psi)	Switch-point Repeatability	Dead-band (psi)
ZPT-U4 *	50-10,000	± 0,5%	50

* Add suffix **T** for factory installation, see ordering matrix.



Pressure Switch ²⁾

- Controls pump, monitors system
- Adjustable pressure 500-10,000 psi
- Includes glycerine filled 15,000 psi pressure gauge G2536L
- Accuracy ± 1,5% of full scale

²⁾ 24 V, requires Electric Box. Not available in combination with pressure transducer.

Accessory Kit Model number	Switch-point Repeatability	Deadband (psi)	Oil Ports (NPT)
ZPS-E3 *	± 2%	115-550	3/8"

* Add suffix **P** for factory installation, see ordering matrix.



Pendants ³⁾

- For pump types with valve operation “W” (No Valve, with Electric Box, without pendant)

³⁾ When ordering Enerpac VE-Series solenoid valve the pendant must be ordered separately. Pendant connection to be plugged into electric box

Pendant Model Number	To be used with Solenoid Valve:
ZCP-1	VE32D
ZCP-3	VE32, VE33, VE43



Heat Exchanger ⁴⁾

- Removes heat from bypass oil to provide cooler operation
- Stabilizes oil viscosity, increasing oil life and reduces wear of pump and other hydraulic components.

⁴⁾ 24 VDC, requires electric box

Accessory Kit Model number	Fits on Reservoir	Weight (lbs)
ZHE-E04 *	1 and 2 gallon	9.0
ZHE-E10 *	2.5, 5, and 10 gallon	9.0

* Add suffix **H** for factory installation, see ordering matrix.

ZE Series



Reservoir Capacity:
1.0-10.0 gal.

Flow at Rated Pressure:
40-200 in³/min.

Motor Size:
1.0-7.5 hp

Maximum Operating Pressure:
10,000 psi



ZHE-Series Heat Exchangers

Heat exchanger stabilizes oil temperature at 130° F at 70° F ambient temperature. Thermal transfer at 5 GPM and 70° F ambient temperature: 900 Btu/hour.

Do not exceed maximum oil flow of 7.0 GPM and maximum pressure of 300 psi. Not suitable for water-glycol or high water based fluids.