

# Instruction Sheet

## W-Series Hydraulic Torque Wrenches

---

## CD with Instruction Sheets in PDF-format

Please find the CD enclosed in the back of this manual

Choose the required product series from the left side of the screen, then click on the required language. The following languages are listed:

- English (GB)
- Français (FR)
- Deutsch (DE)
- Italiano (IT)
- Español (ES)
- Nederlands (NL)
- Portuguese/Brasil (PT)
- Svenska (SE)
- Norsk (NO)
- Suomi (FI)
- Русский (RU)

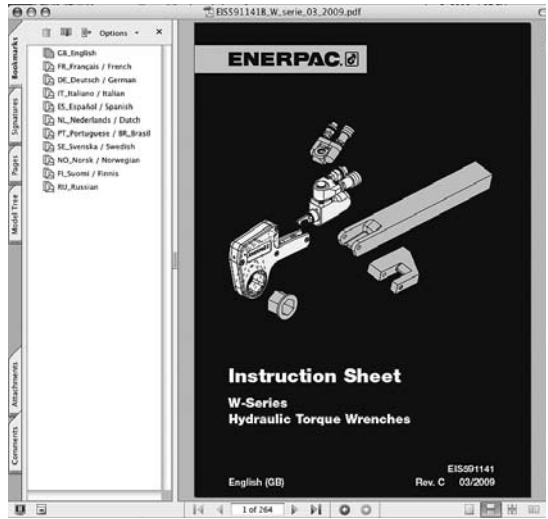

The install program of the Acrobat Reader 6.0 is included on the CD.

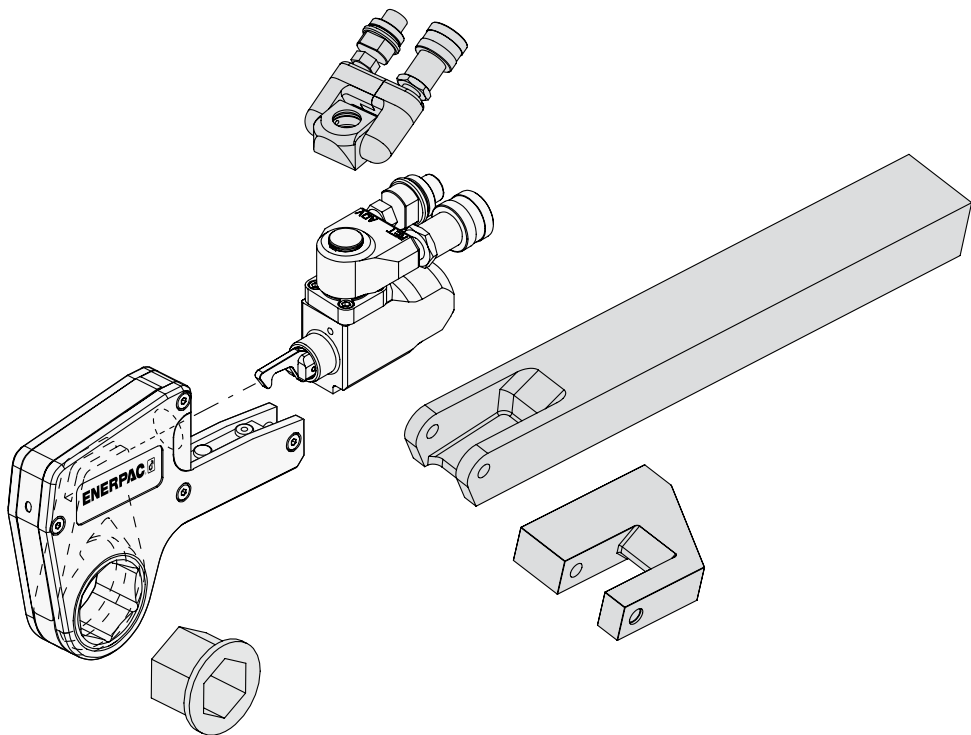

## Index

1	Introduction .....	4
2	Safety .....	4
3	Assembly and adjustments .....	6
4	Operation .....	8
5	Maintenance and troubleshooting .....	10
6	Technical specifications & torque settings .....	13
7	Recommended spare parts .....	17

## 1 Introduction

### Enerpac W-Series

The Enerpac W-series of lightweight hydraulic wrenches have been designed to tighten and loosen nuts and bolts for professional applications. The tool has an interchangeable fastener head for which a wide range of sizes are available. The low profile head greatly increases access in limited space areas by locating directly around the hex nut itself.

The optional TSP-Pro Series Swivel provides 360 degree X-axis and 160 degree Y-axis rotation for better positioning of the wrench and hoses in confined applications.

The integrated reaction foot further enhances the compactness of the tool. The tool easily connects to the range of available Enerpac pumps. Enerpac can supply air, electric or hand operated pumps.

### Delivery instructions

Upon delivery all components must be inspected for damage incurred during shipping. If damage is found the carrier should be notified at once. Shipping damage is not covered by the Enerpac warranty.

### Warranty

- Enerpac guarantees the product only for the purpose for which is intended.
- All Enerpac products are guaranteed against defects in workmanship and materials for as long as you own them.

Any misuse or alteration invalidates the warranty.

- Observe all instructions as laid down in this manual.
- Replace any parts with Enerpac spare parts only.

## CE Declaration of conformity

W2000/W4000/W8000/W15000

Enerpac declares that these models meet the applicable standards and directives issued by the European Community. For a detailed list refer to the separate certification sheet.

## 2 Safety

Be aware that the operator is fully responsible during the operation of this tool. Enerpac is not responsible for damage or injury caused by misuse of this tool. Under some circumstances additional safety requirements may be required. Contact Enerpac immediately if a potentially hazardous situation arises.

Read this manual carefully and observe all safety precautions.

- Make sure you have completed a safety induction training, specific to the work surroundings. The operator should be thoroughly familiar with the controls and the proper use of the tool.
- The operator must be at least 18 years of age.
- Always wear protective headwear, ear protectors, footwear and gloves (at a minimum rigger type gloves) suitable for safe operation of the tool. The protective clothing must not interfere with safe operation of the tool or restrict the ability to communicate with co-workers.
- Make sure your workplace is safe.
- Do not place any part of the body between the reaction foot and the reaction point.

- 
- Do not place any objects between the reaction foot and the reaction point. Keep the hoses away from the reaction points.
  - Do not stand in the line of movement of the tool when it is in operation. If the tool separates from the nut or bolt during operation it will detach in that direction.
  - Tightening and loosening nuts and bolts involves little visible movement. The pressure and loads, however are extreme. Keep your hands away from the fastener being loosened or tightened.
  - Make sure that the spanner used to keep the nut or bolt on the opposite end is secured.
  - Always use Enerpac pumps and hoses.
  - Make sure appropriate guards are always securely in position and free from damage.
  - Maximum pressure is 690 bar (10,000 psi). Never apply more pressure to any tool or accessory than the maximum allowable pressure. Refer to the technical data tables for maximum pressure setting.
  - Make sure that the ratchet size corresponds to the size of the fastener being loosened or tightened. Failure to do so can result in the tool becoming unstable and can lead to catastrophic failure of the tool.
  - Do not abuse or overstress the hoses in any way. Do not bend the hoses excessively.
  - Never carry the tool by its hoses.
  - Always use Enerpac spare parts.
  - Always position the tool for maximum stability.
  - Make sure reaction points are adequate for the forces at work during operation of the tool.
- Be aware that a nut or bolt that breaks off during operation of the tool will become a high velocity projectile.
  - Make sure the reaction point is of a suitable shape.  
For example use an adjacent nut or bolt as a reaction point.
  - When the hex ratchet is placed on the nut or bolt a gap may exist between the reaction foot and the reaction plate. When the tool is operated the reaction foot and point will make forceful contact. Always make sure the tool is stable.
  - Provide adequate support in vertical and inverted applications.
  - The maximum torque output of the tool must always exceed the torque required to loosen or tighten the nut or bolt.
  - The torque required to loosen a nut is variable and may exceed the torque capacity of the tool. Therefore never operate the tool at maximum or close to maximum capacity when loosening a nut or bolt.
  - Never operate the tool with a hydraulic supply connection to the advance side only as this may damage the internal parts.
  - If the wrench is dropped from a height, have the tool inspected before you operate it again.
  - In severe conditions the tool must be cleaned and lubricated more frequently (see section 5.0).
  - Check that the swivel pin screws (see 5.2.1) and gland are tight prior to use.
  - If oil leakage is evident, replace seals accordingly (see section 5.0).
  - Stop operation immediately if a gap appears between the cylinder locating plate and the drive unit. Have the tool inspected and serviced before you operate it again.
-

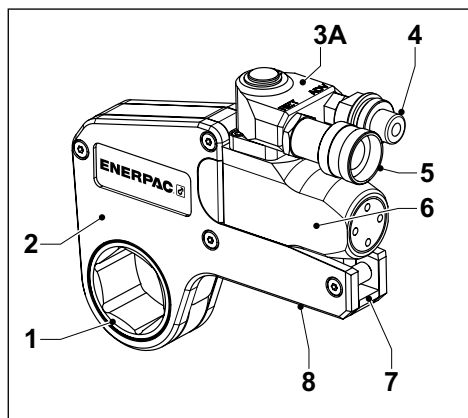

Fig. A

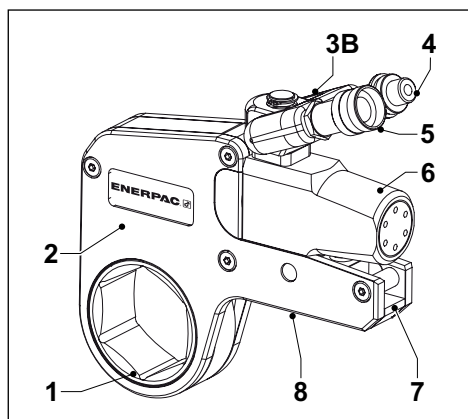

Fig. B

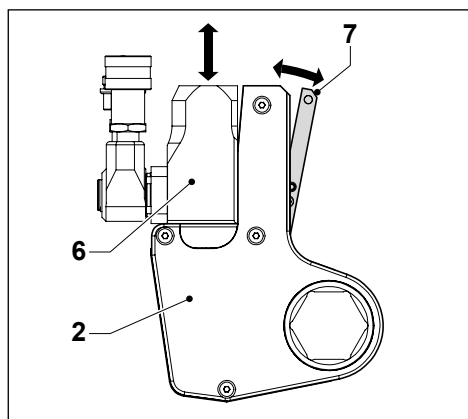

Fig. C

- Make sure to minimize torsional and bending stresses in the tool, the hex ratchet and any accessories.
- Do not strike the tool with a hammer while under a full load. This will invalidate the guarantee.
- Always observe the maintenance instructions.

### 3 Assembly and adjustments

#### 3.1 Overview and features (fig. A or B)

- 1 Hexagon ratchet
- 2 Fastener head
- 3A Swivel coupling or
- 3B TSP-Pro Swivel coupling (optional)
- 4 Advance hose connection
- 5 Return hose connection
- 6 Hydraulic drive unit
- 7 Head release lever
- 8 Reaction foot

#### 3.2 To change the fastener head (fig. C & D)



Make sure to depressurize and disconnect the tool from the hydraulic supply first.

##### 3.2.1 To remove the fastener head

- Make sure the piston is fully retracted.
- Hold the tool with the reaction foot pointing upwards.
- Pull the head release lever (7) outwards.
- Remove the fastener head (2) from the hydraulic drive unit (6).

##### 3.2.2 To attach the fastener head

- Make sure the retract link (9) aligns with the slot (11) in the crank. Rotate the piston rod if necessary.
- Pull the release lever (7) outwards.
- Push the spigot (10) into the cylinder locating plate (12).

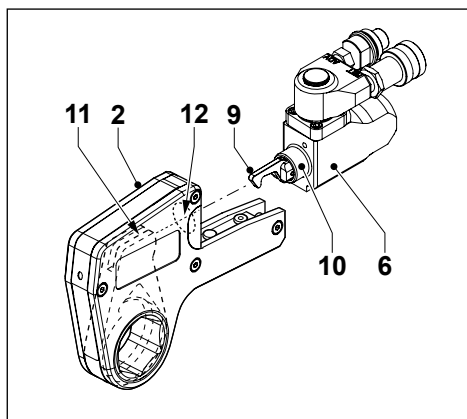

Fig. D

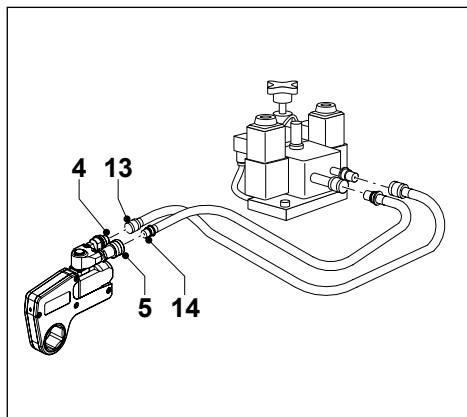

Fig. E

- Push the release lever (7) back into the fastener head (2). Make sure the ball detent clicks into place.



Do not operate the tool if the head release lever is not fully closed.

### 3.3 To connect the hoses (fig. E)



Make sure all accessories meet the pressure requirements.

Make sure the quick connect couplings are securely attached before operating the tool.

The tool is fitted with male and female quick-connect couplings. Use Enerpac twin safety hoses only. Refer to the table below.

Hose model number	Description
THQ-706T	Two hoses, length 6 m (19.5 feet)
THQ-712T	Two hoses, length 12 m (39 feet)

- Remove the hose dust caps.
- Connect the hose with the female coupling (13) to the advance coupling (4).
- Pull the sleeve on the female coupling of the hose over the advance coupling.
- Tighten the sleeve.
- Connect the hose with the male coupling (14) into the return coupling (5).
- Pull the sleeve on the return coupling over the male coupling of the hose.
- Tighten the sleeve.
- Fit the hoses to the pump. Refer to the pump instruction manual.

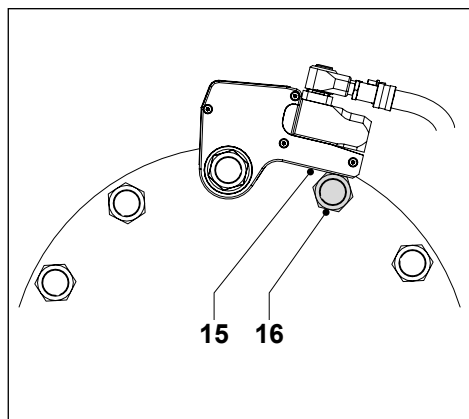

Fig. F

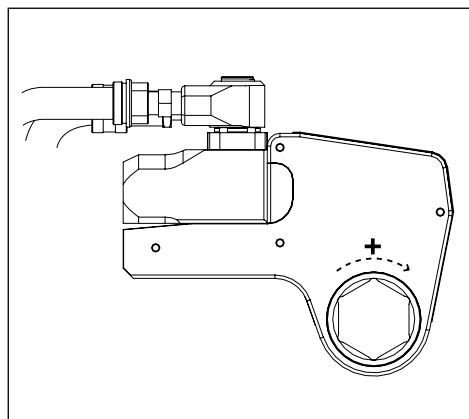

Fig. G

## 4 Operation

### 4.1 Prior to operation

- Make sure the nut or bolt to be fastened is clean and free of dust.
- Make sure the nut or bolt runs correctly on the thread.
- Make sure that the threads and the bearing surface are liberally coated with the correct lubricant or anti-seizure compound.
- Make sure that the spanner used to keep the nut or bolt on the opposite end in place, is of the correct size and that there is an adequate abutment surface.
- Contact Enerpac if a suitable reaction point is not available. Enerpac has extensive experience with providing special reaction devices.

### 4.2 To set the torque

Adjust the pressure on the pump as necessary to set the torque.

### 4.3 To operate the tool (fig. F)

- Position the reaction foot (15) against a suitable reaction point (16). The reaction point will counteract the force caused by operating the tool.
- Start the pump.
- Operate the tool to tighten or loosen the nut or bolt.
- Stop the pump immediately after work has finished.



Do not strike the tool with a hammer while under a full load.

#### 4.3.1 To tighten a nut or bolt (fig. G)

- Position the tool on the nut or bolt with the clockwise (+) side facing upwards.
- Operate the pump until the nut or bolt has been tightened to the required torque.



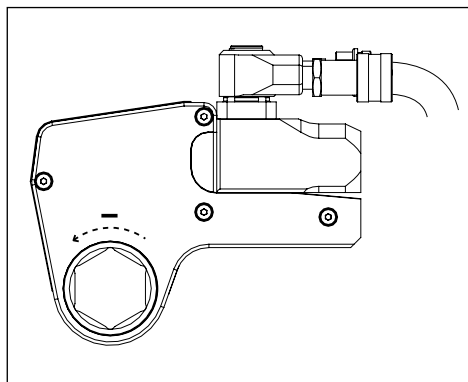

Fig. H

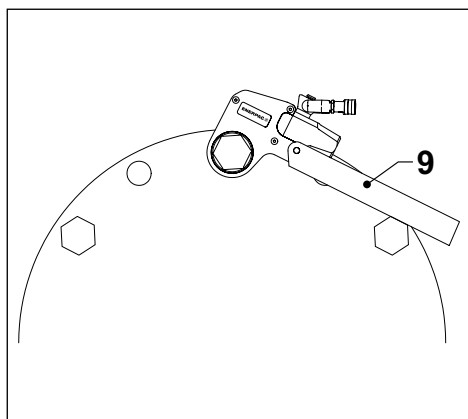

Fig. I

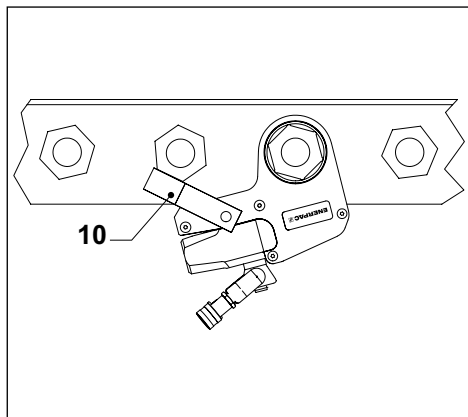

Fig. J

**!** Stop operation immediately if a gap appears between the cylinder locating plate and the drive unit.

#### 4.3.2 To loosen a nut or bolt (fig. H)

- Apply releasing oil to the threads. Allow the oil to soak.
  - Position the tool on the nut or bolt with the anti-clockwise (-) side facing upwards.
  - Operate pump until nut (bolt) is loose.
- !** If the nut or bolt will be re-used avoid excess load when loosening.
- Be aware that when loosening a nut or bolt more torque is usually required than when tightening.
  - Humidity corrosion (rust) requires up to twice the torque required for tightening.
  - Sea water and chemical corrosion requires up to two and a half times the torque required for tightening.
  - Heat corrosion requires up to three times the torque required for tightening.

**!** Be aware that when loosening a nut or bolt shock loading can occur. Do not apply more than 75% of the wrench's maximum torque when loosening nuts or bolts.

#### 4.3.3 Using extended reaction arm (fig. I)

- Position the WTE-series extended reaction arm (#9) against a suitable reaction point. The reaction point will counteract the force caused by operating the tool.
- Follow instructions in section 4.3.

#### 4.3.4 Using reaction paddle (fig. J)

- Position the WRP-series reaction paddle (#10) against a suitable reaction point. The reaction point will counteract the force caused by operating the tool.
- Follow instructions in section 4.3.

## 5 Maintenance and troubleshooting



Preventative maintenance can be carried out by the user. Full maintenance must be carried out by an approved and authorized technician appointed by Enerpac.

Recommended service intervals are:

- 3 months – Heavy Duty use
- 6 months – Normal use
- 12 months – Infrequent use.

- Non destructive testing must be carried out if the tool has been used under severe conditions.

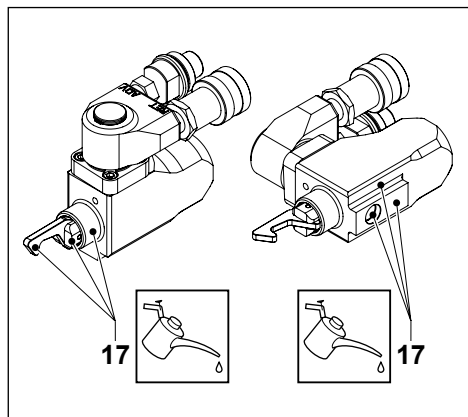

Fig. K

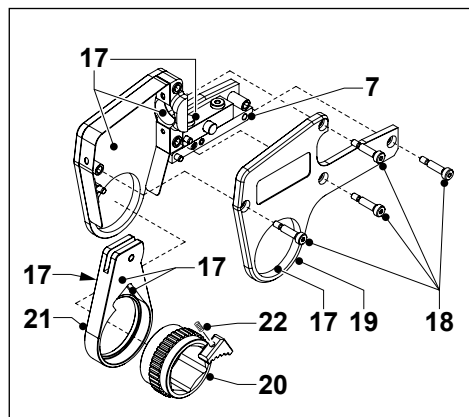

Fig. L

### 5.1 Preventative Maintenance (Fig. K & L)

#### 5.1.1 The hydraulic drive unit

- Check tightness of swivel or TSP Pro-series manifold pin screws (see 5.2.1) and gland.
- Pressurise the drive unit to maximum pressure (Advance and Retract), and check for any signs of leakage.
- Any damaged components or seals must be replaced.
- Dry all components and apply a thin coat of molybdenum disulphide as indicated (17).



Molybdenum disulphide is available from Enerpac.

#### 5.1.2 The fastener head

- Remove the head from the drive unit.
- Remove the screws (18). Lift and remove the sideplates (19).
- Remove the hex ratchet (20), spring loaded drive shoe (21), and compression spring (22).
- Clean all exposed components with a mild solvent.
- Inspect all parts for damage.
- Dry all components. Apply a thin coat of molybdenum disulphide as indicated (17).



Do not apply any lubricant to the ratchet or drive shoe teeth.

## 5.2 Full maintenance

### 5.2.1 The hydraulic drive unit

- Remove the circlip from the swivel coupling.
- Remove the couplings.
- Remove the swivel-coupling block from the drive unit.
- Remove the pin by removing the pin retaining screws.
- Remove all 'O' rings from the pin.
- Carefully hold the cylinder body to unscrew the cylinder gland.
- Hold the two flat sides of the piston rod with a spanner. The rod is located at the spigot.
- Remove the button head cap screw from the piston.
- Remove the piston rod from the cylinder spigot end.
- Remove the piston from the cylinder gland end, using a suitable drift.
- Clean all exposed components with a mild solvent.
- Inspect all parts for damage.
- Carry out non destructive testing by magnetic particle inspection on the following components:
  - Cylinder
  - Piston rod
- Apply a small amount of Loctite 243 to the threads of the piston retaining screw before reassembly.
- Apply a small amount of Loctite 243 to the threads in the drive unit, assemble the swivel pin and tighten the degreased retaining screws, as follows:
  - a) W2000 and W4000:  
(M4 screws) – 5,1 Nm
  - b) W8000 and W15000:  
(M5 screws) – 10,2 Nm.

- Reverse the procedure to reassemble
- Pressurise the assembled drive unit to max pressure (Advance and Retract), and check for any signs of leakage.



When reassembling the drive unit make sure that the piston rod is inserted through the cylinder spigot end. When reassembling the drive unit make sure that the piston is inserted through the gland end. Tap the piston gently into place against the piston rod.

### 5.2.2 The fastener head

- Strip down and clean all exposed components with a mild solvent.
- Drift out the roll pin holding the cylinder retaining pin, and remove.
- Inspect all parts for damage.
- Carry out non destructive testing by magnetic particle inspection on the following components:
  - Sideplates
  - Locating plate
  - Pin retainer
  - Reaction foot
  - Crank
  - Ratchet
  - Drive shoe
  - Cylinder retaining pin
  - Spacer retaining pin
- Dry all components. Apply a thin coat of molybdenum disulphide as indicated (17).

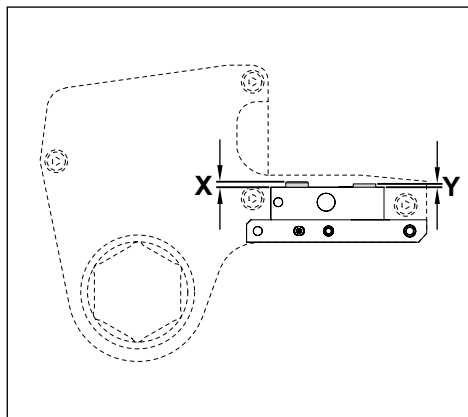

Fig. M

- As a check, figure M and the table below indicates the correct height for the drive unit retaining pin (X) and the fail safe pin (Y).

	X	X	Y	Y
	(mm)	(inch)	(mm)	(inch)
W2000	4,00	.157	3,00	.118
W4000	5,00	.197	3,00	.118
W8000	6,00	.236	4,00	.157
W15000	7,00	.275	6,00	.236

- Reverse the procedure to reassemble the tool.

### 5.3 Trouble shooting

#### 5.3.1 Drive Unit

Symptom	Cause	Remedy
Cylinder does not advance or retract	Quick-connect coupling is damaged	Replace the coupling
	Quick connect- coupling is not connected	Reconnect the hoses and couplings securely
	Dirt in the direction control valve on the pumping unit	Disassemble the unit and clean the valve
Cylinder does not build up pressure	Piston seal leaks	Replace the seals
	Pump does not build up pressure	Adjust the pressure
Cylinder leaks	Pump is defective	Refer to the pump manual
	Seal failure	Replace the cylinder seals
Cylinder operates backwards	Connections are reversed	Reconnect the hoses

#### 5.3.2 Fastener head

Symptom	Cause	Remedy
Ratchet returns on retract stroke	Broken drive shoe	Replace the drive shoe
Ratchet does not take successive strokes	Defective drive shoe	Replace the drive shoe
	Lubricant on the ratchet and/or drive shoe splines	Disassemble the head and remove the lubricant from splines

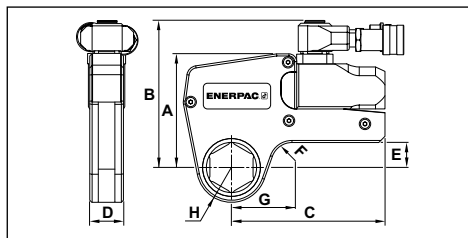

Fig. N

\* Note on 6.1 fastener head capacity: When using reducer inserts with wall thickness less than those listed below the insert may experience reduced component life:

W2000	3,50 mm (0.14")
W4000	4,69 mm (0.18")
W8000	6,0 mm (0.24")
W15000	6,69 mm (0.26")

## 6 Technical specifications

### 6.1 Capacities and dimensions (fig. N)

		W2000	W4000	W8000	W15000
Fastener head capacity *	mm	30 - 60	36 - 85	50 - 105	65 - 115
	inch	1 1/8 - 2 3/16	1 5/16 - 3 3/8	1 7/8 - 4 1/8	2 7/16 - 4 5/8
Maximum operating pressure	bar	690	690	690	690
	psi	10,000	10,000	10,000	10,000
Max. torque	at 690 bar	Nm 2.712	5.423	10.846	20.337
	at 10,000 psi	Ft.lbs 2,000	4,000	8,000	15,000
Min. torque		Nm 271	542	1.084	2.033
		Ft.lbs 200	400	800	1,500
Dimensions	A	mm (inch) 109 (4.29)	136 (5.35)	172 (6.77)	207 (8.15)
	B	mm (inch) 141 (5.55)	167 (6.57)	205 (8.07)	240 (9.45)
	C	mm (inch) 148 (5.83)	178 (7.01)	208 (8.19)	253 (9.96)
	D	mm (inch) 32,0 (1.26)	41,0 (1.61)	52,5 (2.07)	63,0 (2.48)
	E	mm (inch) 24,0 (.94)	32,8 (1.29)	41,9 (1.65)	50,0 (1.97)
	F	mm (inch) 20 (.79)	20 (.79)	25 (.98)	20 (.79)
	Weight (without head)	kg (lbs)	1,4 (3.1)	2,0 (4.4)	3,0 (6.6)

#### 6.1.1 Dimensions using WTE-series extended reaction arm (fig. O)

A1	mm (inch)	56 (2.20)	66 (2.59)	85 (3.35)	102 (4.05)
B1	mm (inch)	398 (15.67)	436 (17.17)	449 (17.68)	498 (19.60)
C1	mm (inch)	76 (2.99)	74 (2.90)	66 (2.60)	72 (2.80)

#### 6.1.2 Dimensions using WRP-series reaction paddle (fig. P)

A2	mm (inch)	84 (3.31)	109 (4.29)	137 (5.39)	165 (6.50)
B2	mm (inch)	148 (5.83)	190 (7.48)	223 (8.78)	257 (10.12)
C2	mm (inch)	45 (1.77)	59 (2.32)	69 (2.72)	87 (3.43)
K	mm (inch)	16 (0.63)	21 (0.83)	26 (1.02)	32 (1.26)
L	mm (inch)	35 (1.38)	47 (1.85)	57 (2.25)	69 (2.72)

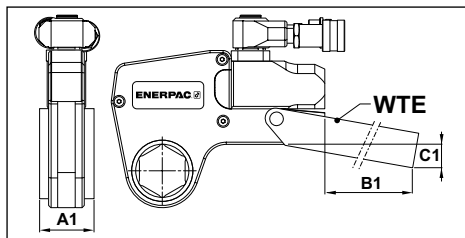

Fig. O

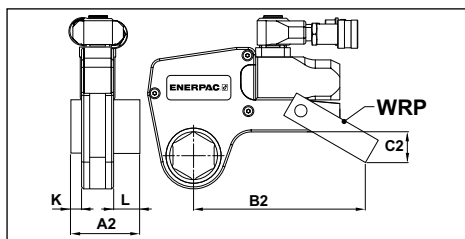

Fig. P

## 6.2 Fastener head capacities (fig. N)

### 6.2.1 Metric system table

Drive unit	Fastener head	Hexagon size mm	(H) mm	(G) mm	Weight kg
W2000	W2107	36	31,0	53,7	1,9
	W2108	38	33,5	58,2	2,0
	W2110	41	33,5	58,2	2,0
	W2113	46	36,5	60,5	2,0
	W2200	50	39,0	63,1	2,0
	W2203	55	41,8	68,6	2,1
	W2206	60	44,5	64,8	2,2
W4000	W4203	55	44,0	73,4	3,8
	W4206	60	46,5	70,6	3,9
	W4208	63	49,5	76,2	3,9
	W4209	65	49,5	76,2	3,9
	W4212	70	52,5	78,3	4,0
	W4215	75	55,5	81,6	4,1
	W4302	80	58,5	83,5	4,2
W8000	W8209	65	56,0	84,8	7,8
	W8212	70	56,0	84,8	7,8
	W8215	75	58,0	85,0	7,8
	W8302	80	60,5	89,5	7,9
	W8085M	85	66,0	92,2	8,1
	W8090M	90	74,0	102,9	8,7
	W8312	95	74,0	102,9	8,8
W15000	W15302	80	64,5	92,9	13,7
	W15085M	85	69,5	96,6	14,0
	W15090M	90	75,0	101,8	14,4
	W15312	95	75,0	101,8	14,5
	W15402	105	80,5	103,1	14,7
	W15110M	110	87,5	114,8	15,0
	W15115M	115	87,5	114,8	15,3

## 6.2.2 Imperial system table

Drive unit	Fastener head	Hexagon size inch	(H) inch	(G) inch	Weight lbs
W2000	W2107	1 <sup>7</sup> / <sub>16</sub>	1.22	2.11	4.2
	W2108	1 <sup>1</sup> / <sub>2</sub>	1.32	2.29	4.4
	W2110	1 <sup>5</sup> / <sub>8</sub>	1.32	2.29	4.4
	W2113	1 <sup>13</sup> / <sub>16</sub>	1.44	3.38	4.4
	W2200	2	1.54	2.48	4.4
	W2203	2 <sup>3</sup> / <sub>16</sub>	1.65	2.70	4.6
	W2206	2 <sup>3</sup> / <sub>8</sub>	1.75	2.55	4.8
	W4000	W4203	2 <sup>3</sup> / <sub>16</sub>	1.73	2.89
W4206		2 <sup>3</sup> / <sub>8</sub>	1.83	2.78	8.6
W4208		2 <sup>1</sup> / <sub>2</sub>	1.95	3.00	8.6
W4209		2 <sup>9</sup> / <sub>16</sub>	1.93	3.00	8.6
W4212		2 <sup>3</sup> / <sub>4</sub>	2.07	3.08	8.8
W4215		2 <sup>15</sup> / <sub>16</sub>	2.19	3.21	9.0
W4302		3 <sup>1</sup> / <sub>8</sub>	2.30	3.29	9.3
W8000		W8209	2 <sup>9</sup> / <sub>16</sub>	2.20	3.34
	W8212	2 <sup>3</sup> / <sub>4</sub>	2.20	3.34	17.2
	W8215	2 <sup>15</sup> / <sub>16</sub>	2.28	3.35	17.2
	W8302	3 <sup>1</sup> / <sub>8</sub>	2.38	3.52	17.4
	W8308	3 <sup>1</sup> / <sub>2</sub>	2.60	3.63	17.9
	W8312	3 <sup>3</sup> / <sub>4</sub>	2.91	4.05	19.4
	W8314	3 <sup>7</sup> / <sub>8</sub>	2.91	4.05	19.2
	W15000	W15302	3 <sup>1</sup> / <sub>8</sub>	2.54	3.66
W15308		3 <sup>1</sup> / <sub>2</sub>	2.74	3.80	28.7
W15312		3 <sup>3</sup> / <sub>4</sub>	2.95	4.01	31.8
W15314		3 <sup>7</sup> / <sub>8</sub>	2.95	4.01	31.8
W15402		4 <sup>1</sup> / <sub>8</sub>	3.17	4.06	32.4
W15404		4 <sup>1</sup> / <sub>4</sub>	3.17	4.06	32.4
W15410I		4 <sup>5</sup> / <sub>8</sub>	3.44	4.52	33.7

## 6.3 Torque settings

To set the torque, adjust the pump pressure according to the following calculation:

– Pump pressure = Torque / Torque factor

### Torque factor

	W2000	W4000	W8000	W15000
Metric system	3,932	7,863	15,728	29,488
Imperial system	0.2	0.4	0.8	1.5

## 6.3.1 Metric system table

Pump pressure (bar)	W2000 Torque (Nm)	W4000 Torque (Nm)	W8000 Torque (Nm)	W15000 Torque (Nm)
69	272	543	1085	2034
124	489	977	1953	3661
179	706	1411	2821	5288
207	814	1627	3254	6102
234	922	1844	3688	6915
262	1031	2061	4122	7729
290	1139	2278	4556	8542
317	1248	2495	4990	9356
345	1356	2712	5424	10.169
372	1465	2929	5858	10.982
400	1573	3146	6291	11.796
428	1682	3363	6725	12.609
455	1790	3580	7159	13.423
483	1899	3797	7593	14.236
510	2007	4014	8027	15.050
538	2116	4231	8461	15.863
566	2224	4448	8895	16.677
593	2332	4664	9328	17.490
621	2441	4881	9762	18.304
648	2549	5098	10.196	19.117
690	2712	5424	10.847	20.337

## 6.3.2 Imperial system table

Pump pressure (psi)	W2000 Torque (Ft.lbs)	W4000 Torque (Ft.lbs)	W8000 Torque (Ft.lbs)	W1500 Torque (Ft.lbs)
1,000	200	400	800	1,500
1,800	360	720	1,440	2,700
2,600	520	1,040	2,080	3,900
3,000	600	1,200	2,400	4,500
3,400	680	1,360	2,720	5,100
3,800	760	1,520	3,040	5,700
4,200	840	1,680	3,360	6,300
4,600	920	1,840	3,680	6,900
5,000	1,000	2,000	4,000	7,500
5,400	1,080	2,160	4,320	8,100
5,800	1,160	2,320	4,640	8,700
6,200	1,240	2,480	4,960	9,300
6,600	1,320	2,640	5,280	9,900
7,000	1,400	2,800	5,600	10,500
7,400	1,480	2,960	5,920	11,100
7,800	1,560	3,120	6,240	11,700
8,200	1,640	3,280	6,560	12,300
8,600	1,720	3,440	6,880	12,900
9,000	1,800	3,600	7,200	13,500
9,400	1,880	3,760	7,520	14,100
10,000	2,000	4,000	8,000	15,000



## 7 Recommended spare parts

### 7.1 To order spare parts

Quote the information below when ordering spare parts:

- The assembly name and serial numbers.
- The component name and part number.
- The contract number or approximate date of purchase.

All item numbers quoted below refer to the repair parts sheets. For specific component part numbers refer to the appropriate bill of materials.

### 7.2 Hydraulic drive unit

#### 7.2.1

##### 1 Seal kit (item 8.0)

- 1 Cylinder gland 'O' ring
- 1 Piston seal
- 1 Piston rod 'O' ring
- 1 Cylinder rod seal
- 2 Swivel manifold 'O' rings
- 2 Swivel manifold 'O' ring
- 1 Swivel manifold 'O' ring
- 1 Swivel manifold circlip

#### 7.2.2

##### 1 Swivel manifold seal kit (item 9.0)

- 2 Swivel manifold 'O' rings
- 2 Swivel manifold 'O' rings
- 1 Swivel manifold 'O' ring
- 1 Swivel manifold circlip
- 4 TSP-Swivel arm O' ring (TSP only)
- 1 Sockethead Cap Screw (TSP only)

#### 7.2.3

##### 1 Spares kit (item 6.0)

- 1 Male coupling
- 1 Female coupling
- 1 Male adaptor
- 1 Swivel manifold circlip
- 1 Piston retaining screw
- 4 Swivel manifold pin retaining screws
- 1 Retract link spring
- 1 Retract link retaining pin
- 2 Drive shoe compression springs
- 4 Sideplate retaining screws

### 7.3 Recommended tool kit

#### W2000

- 1 7/8" spanner
- 1 3/4" spanner
- 1 5/8" spanner
- 1 Circlip pliers
- 1 Seal extraction tool
- 1 16 mm spanner
- 1 ø 4 mm x 5 mm LG x 20 mm  
PCD pin spanner
- 1 5 mm Allen key
- 1 4 mm Allen key
- 1 3 mm Allen key
- 1 2,5 mm Allen key
- 1 3 mm Terminal screwdriver

#### W4000

- 1 7/8" spanner
- 1 3/4" spanner
- 1 5/8" spanner
- 1 Circlip pliers
- 1 Seal extraction tool
- 1 7/8" spanner
- 1 ø 4 mm x 5 mm LG x 25 mm  
PCD pin spanner
- 1 6 mm Allen key
- 1 4 mm Allen key
- 1 3 mm Allen key
- 1 2,5 mm Allen key
- 1 3 mm Terminal screwdriver

#### W8000

- 1 7/8" spanner
- 1 3/4" spanner
- 1 5/8" spanner
- 1 Circlip pliers
- 1 Seal extraction tool
- 1 1 1/8" spanner
- 1 ø 4 mm x 5 mm LG x 30 mm  
PCD pin spanner
- 1 10 mm Allen key
- 1 4 mm Allen key
- 1 5 mm Allen key
- 1 4 mm Allen key
- 1 2,5 mm Allen key
- 1 3 mm Terminal screwdriver

#### W15000

- 1 7/8" spanner
- 1 3/4" spanner
- 1 5/8" spanner
- 1 Circlip pliers
- 1 Seal extraction tool
- 1 1 3/8" spanner
- 1 ø 4 mm x 5 mm LG x 40 mm  
PCD pin spanner
- 1 10 mm Allen key
- 1 4 mm Allen key
- 1 6 mm Allen key
- 1 4 mm Allen key
- 1 2,5 mm Allen key
- 1 3 mm Terminal screwdriver.

Please contact Enerpac if the CD is not included,  
or visit [www.enerpac.com](http://www.enerpac.com) for a download of the manual.



## **Africa**

ENERPAC Middle East FZE  
Office 423, JAFZA 15  
P.O. Box 18004  
Jebel Ali, Dubai  
United Arab Emirates  
Tel: +971 (0)4 8872686  
Fax: +971 (0)4 8872687

## **Australia and New Zealand**

Actuant Australia Ltd.  
Block V Unit 3  
Regents Park Estate  
391 Park Road  
Regents Park NSW 2143  
(P.O. Box 261) Australia  
Tel: +61 297 438 988  
Fax: +61 297 438 648

## **Brazil**

Power Packer do Brasil Ltda.  
Rua dos Inocentes, 587  
04764-050 - Sao Paulo (SP)  
Tel: +55 11 5687 2211  
Fax: +55 11 5686 5583  
Toll Free: 0800 891 5770  
[vendabrasil@enerpac.com](mailto:vendabrasil@enerpac.com)

## **Canada**

Actuant Canada Corporation  
6615 Ordan Drive, Unit 14-15  
Mississauga, Ontario L5T 1X2  
Tel: +1 905 564 5749  
Fax: +1 905 564 0305  
Toll Free:  
Tel: +1 800 268 4987  
Fax: +1 800 461 2456

### **Technical Inquiries:**

[techservices@enerpac.com](mailto:techservices@enerpac.com)

## **China**

Actuant Industries Co. Ltd.  
No. 6 Nanjing Road,  
Taicang Economic Dep Zone  
Jiangsu, China  
Tel: +86 0512 5328 7529  
+86 0512 5328 7500 7529  
Fax: +86 0512 5335 9690

## **Actuant China Ltd. (Peking)**

709B Diyang Building  
Xin No. 2  
Dong San Huan North Rd.  
Beijing City, 100028 China  
Tel: +86 10 845 36166  
Fax: +86 10 845 36220

## **France, Switzerland francophone**

ENERPAC Une division de ACTUANT  
France S.A.  
ZA de Courtaboeuf  
32, avenue de la Baltique  
91140 Villebon/Yvette, France  
Tel: +33 1 60 13 68 68  
Fax: +33 1 69 20 37 50

## **Germany, Austria, Switzerland, Greece, Baltic States, Central and Eastern Europe**

ENERPAC GmbH  
P.O. Box 300113  
D-40401 Düsseldorf  
Willstätterstrasse 13  
D-40549 Düsseldorf, Germany  
Tel: +49 211 471 490  
Fax: +49 211 471 49 28

## **India**

ENERPAC Hydraulics Pvt. Ltd.  
No. 1A, Peenya Industrial Area  
II<sup>nd</sup> Phase, Bangalore, 560 058  
India  
Tel: +91 80 40 792 777  
Fax: +91 80 40 792 792

## **Italy**

ENERPAC S.p.A.  
Via Canova 4  
20094 Corsico (Milano)  
Tel: +39 02 4861 111  
Fax: +39 02 4860 1288

## **Japan**

Applied Power Japan LTD KK  
Besshocho 85-7  
Kita-ku, Saitama-shi 331-0821  
Japan  
Tel: +81 48 662 4911  
Fax: +81 48 662 4955

## **Middle East, Turkey and Caspian Sea**

ENERPAC Middle East FZE  
Office 423, JAFZA 15  
P.O. Box 18004  
Jebel Ali, Dubai  
United Arab Emirates  
Tel: +971 (0)4 8872686  
Fax: +971 (0)4 8872687

## **Russia and CIS**

(excl. Caspian Sea Countries)  
Actuant LLC  
Admiral Makarov Street 8  
125212 Moscow  
Russia  
Tel: +7-495-9809091  
Fax: +7-495-9809092

## **Singapore**

Actuant Asia Pte Ltd.  
37C, Benoi Road Pioneer Lot,  
Singapore 627796  
Tel: +65 68 63 0611  
Fax: +65 64 84 5669  
Toll Free:  
Tel: +1800 363 7722  
Technical Inquiries:  
[techsupport@enerpac.com.sg](mailto:techsupport@enerpac.com.sg)

## **South Korea**

Actuant Korea Ltd.  
3Ba 717,  
Shihwa Industrial Complex  
Jungwang-Dong, Shihung-Shi,  
Kyunggi-Do  
Republic of Korea 429-450  
Tel: +82 31 434 4506  
Fax: +82 31 434 4507

## **Spain and Portugal**

ENERPAC SPAIN, S.L.  
Avda. Los Frailes, 40 - Nave C & D  
Pol. Ind. Los Frailes  
28814 DAGANZO DE ARRIBA  
(Madrid) Spain  
Tel: +34 91 661 11 25  
Fax: +34 91 661 47 89

## **Sweden, Denmark, Norway, Finland and Iceland**

Enerpac Scandinavia AB  
Fabriksgatan 7  
412 50 Gothenburg  
Sweden  
Tel: +46 (0) 31 7990281  
Fax: +46 (0) 31 7990010  
Inquiries:  
[Scandinavianinquiries@enerpac.com](mailto:Scandinavianinquiries@enerpac.com)

## **The Netherlands, Belgium and Luxembourg**

ENERPAC B.V.  
Galvanistraat 115, 6716 AE Ede  
P.O. Box 8097, 6710 AB Ede  
The Netherlands  
Tel: +31 318 535 911  
Fax: +31 318 525 613  
+31 318 535 848

### **Inquiries:**

[beneluxinquiries@enerpac.com](mailto:beneluxinquiries@enerpac.com)

## **United Kingdom and Ireland**

ENERPAC Ltd.,  
Bentley Road South  
Darlaston, West Midlands  
WS10 8LQ, England  
Tel: +44 (0)121 50 50 787  
Fax: +44 (0)121 50 50 799

## **USA, Latin America and Caribbean**

ENERPAC  
P.O. Box 3241  
6100 N. Baker Road  
Milwaukee, WI 53209 USA  
Tel: +1 262 781 6600  
Fax: +1 262 783 9562  
User inquiries:  
+1 800 433 2766

### **Distributor inquiries/orders:**

+1 800 558 0530

### **Technical Inquiries:**

[techservices@enerpac.com](mailto:techservices@enerpac.com)